

**1** EXAMPLE POST LAYOUT  
PLAN VIEW

AGS Stainless Clearview® Railing Systems are designed to meet the requirements of the latest edition of the IRC/IBC.

**NOTES:**

1. TOP RAIL NOT SHOWN FOR CLARITY.
2. ALL PARTS AND COMPONENTS MADE WITH 316 STAINLESS STEEL UNLESS NOTED OTHERWISE.

**LEGEND**

- DETAIL ID
- SHEET ID
- ELEVATION ID
- SHEET ID
- TOP MOUNT POST
- CENTERLINE
- FF** FINISHED FLOOR
- TYP TYPICAL CONDITION APPLIES ELSEWHERE AT SIMILAR CONDITIONS

**NOTES:**

1. TOP RAIL SHOULD BE SELECTED SO THAT ALL GOVERNING CODE REQUIREMENTS ARE SATISFIED. THESE INCLUDE SHAPE, STRENGTH AND RAILING HEIGHT.
2. DECK STRUCTURE CAN VARY GREATLY. IT IS THE RESPONSIBILITY OF THE CUSTOMER TO VERIFY THAT THE SUPPORTING STRUCTURE IS ADEQUATE TO MEET THE LOAD REQUIREMENTS OF THE GOVERNING BUILDING CODE(S). AGS Stainless Inc. RECOMMENDS CONSULTING A DESIGN OR CONSTRUCTION PROFESSIONAL TO ADDRESS THESE ISSUES.

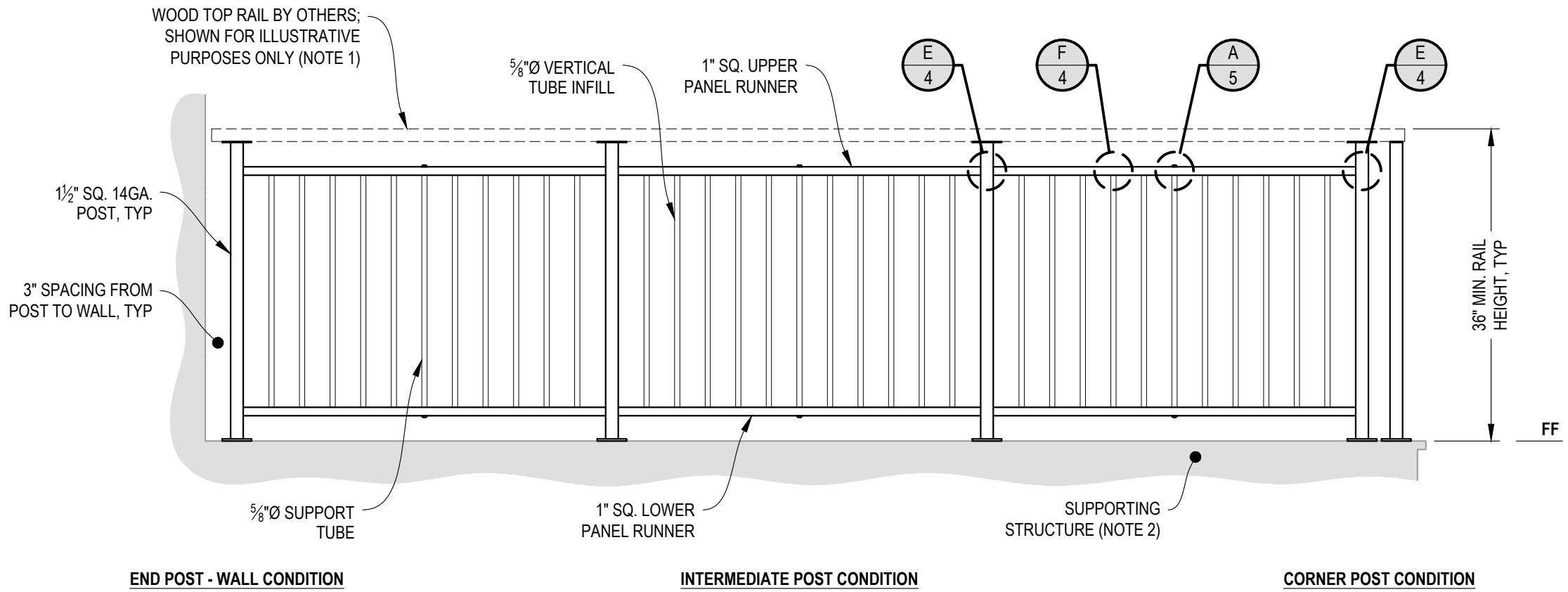

**A** **TYPICAL RAILING CONDITION**  
 ELEVATION

VERTICAL OLYMPUS SPECIFICATION DRAWING

\*\* RESIDENTIAL \*\*

36" TOP MOUNT - WOOD TOP

DWG # TM36W  
 SCALE NONE  
 DATE 2026  
 SHEET

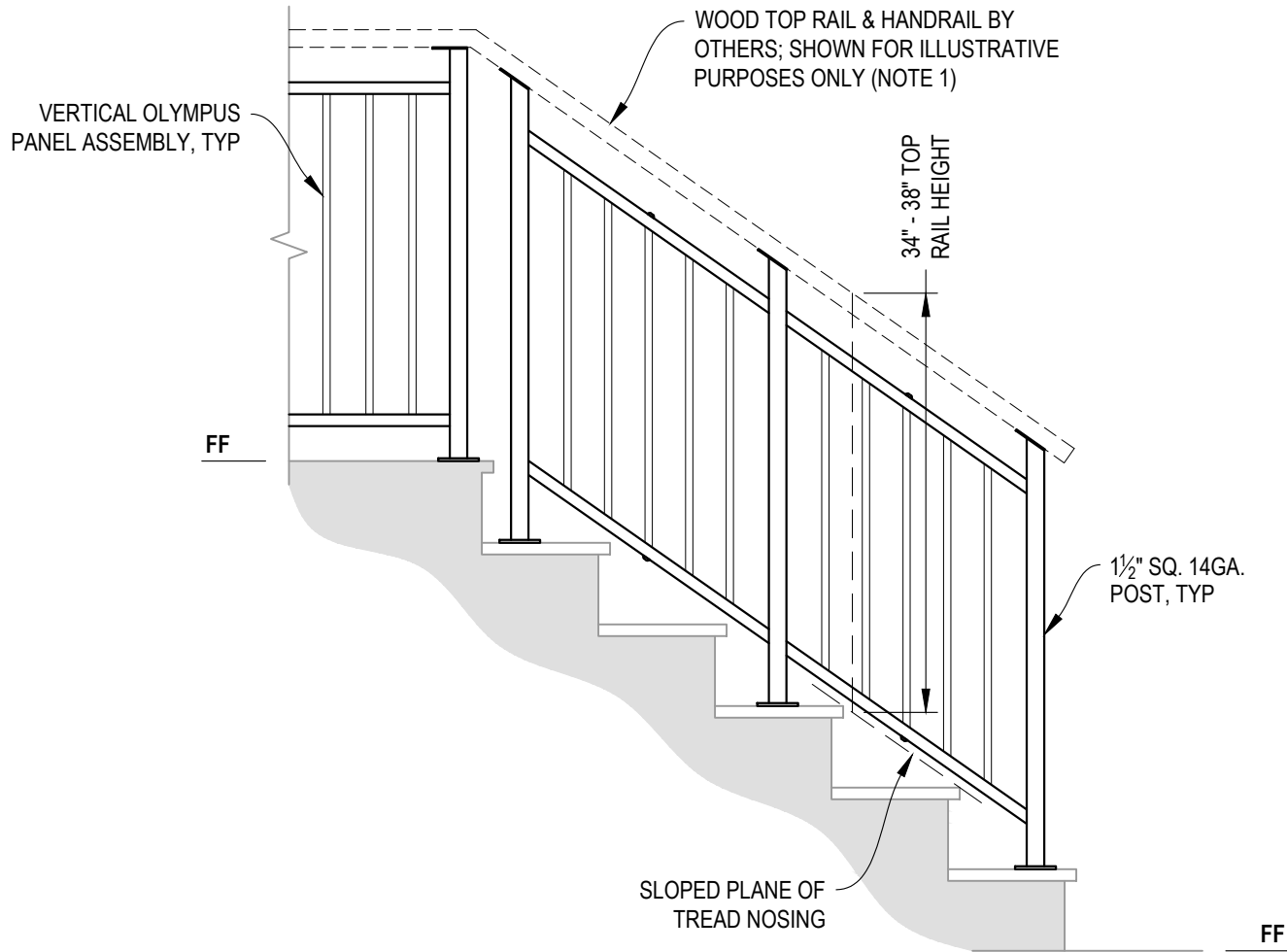

**NOTES:**

1. TOP RAIL SHOULD BE SELECTED SO THAT ALL GOVERNING CODE REQUIREMENTS ARE SATISFIED. THESE INCLUDE SHAPE, STRENGTH, AND RAILING HEIGHT.
2. STAIR CONSTRUCTION VARIES GREATLY. AS-BUILT CONDITIONS MAY ALTER RAILING DESIGN, INCLUDING POST LOCATION & MOUNTING, INFILL SPACING, AND TOP RAIL LAYOUT.

**A** STAIR  
ELEVATION

AGS Stainless Clearview® Railing Systems are designed to meet the requirements of the latest edition of the IRC/IBC.

7873 NE DAY ROAD  
BAINBRIDGE ISLAND, WA 98110  
PHONE - (888) 842-9492  
WWW.AGSSTAINLESS.COM

**AGS stainless**  
CLEARVIEW® Railing Systems

VERTICAL OLYMPUS SPECIFICATION DRAWING  
\*\* RESIDENTIAL \*\*  
36" TOP MOUNT - WOOD TOP

DWG #	TM3W
SCALE	NONE
DATE	2026
SHEET	

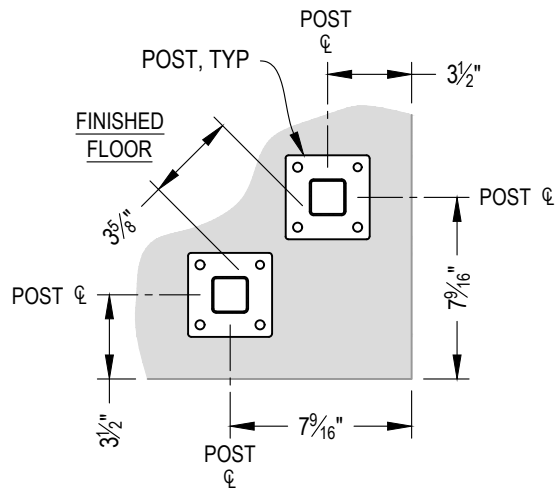

NOTE: 90° SHOWN, OTHER ANGLES SIMILAR

**A** TYPICAL 90° TOP MOUNT OUTSIDE CORNER  
DETAIL

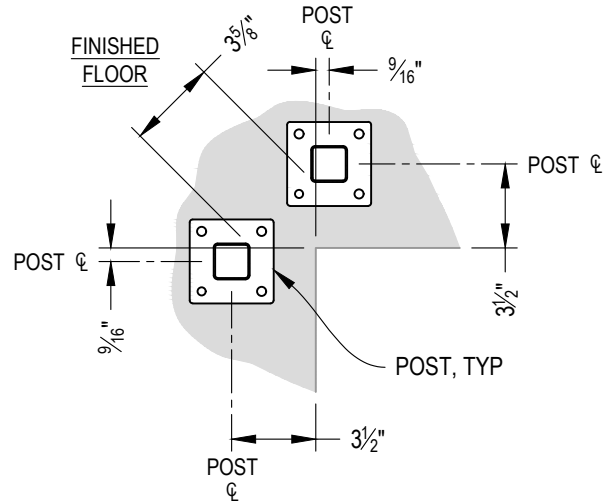

NOTE: 90° SHOWN, OTHER ANGLES SIMILAR

**B** TYPICAL 90° TOP MOUNT INSIDE CORNER  
DETAIL

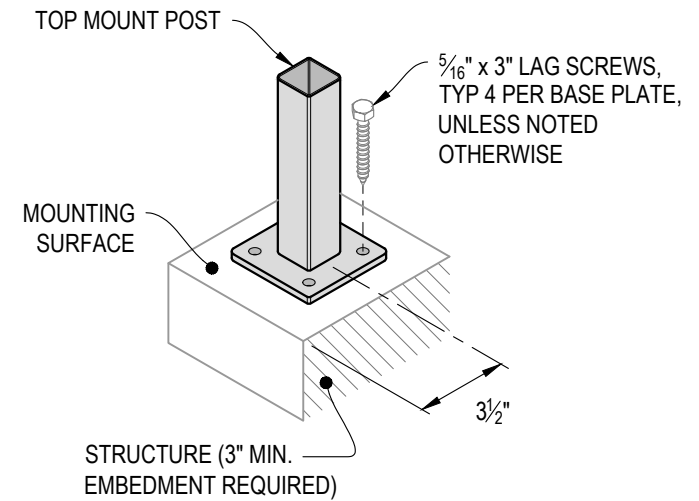

**C** TYPICAL POST MOUNTING - TOP MOUNT  
DETAIL

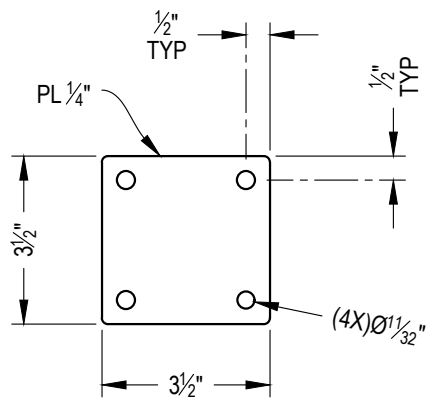

**D** TYPICAL BASE PLATE  
DETAIL

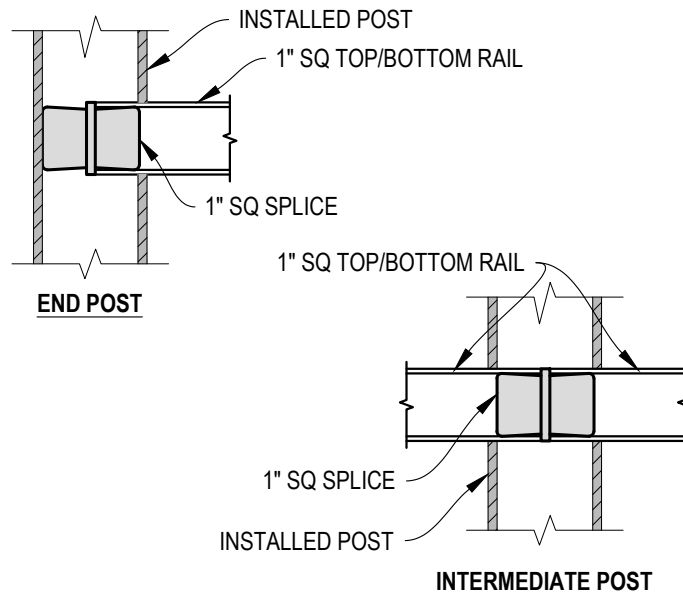

**E** FITTING INSTALLATION - VERTICAL PANEL RAIL SPLICE  
DETAIL

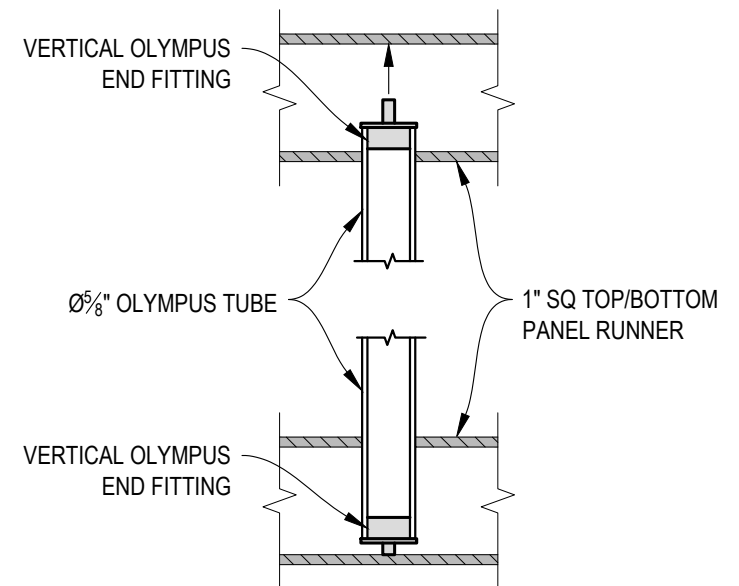

**F** FITTING INSTALLATION - OLYMPUS INSERT  
DETAIL

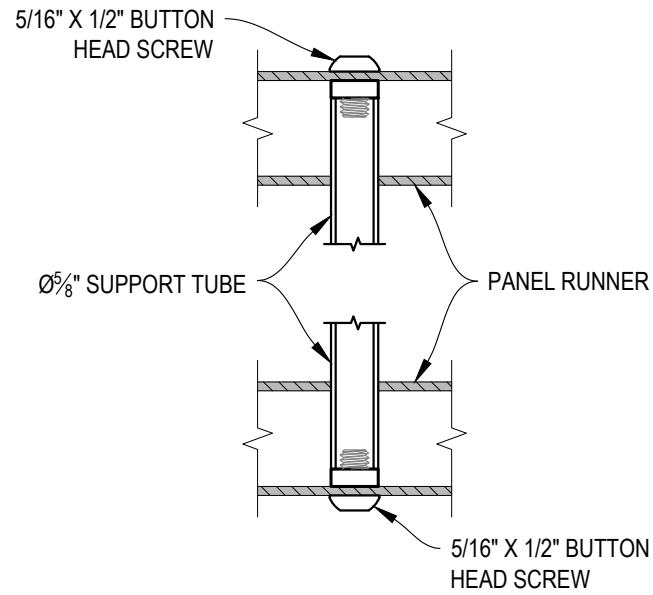

**A** FITTING INSTALLATION - MIDDLE SUPPORT TUBE  
DETAIL

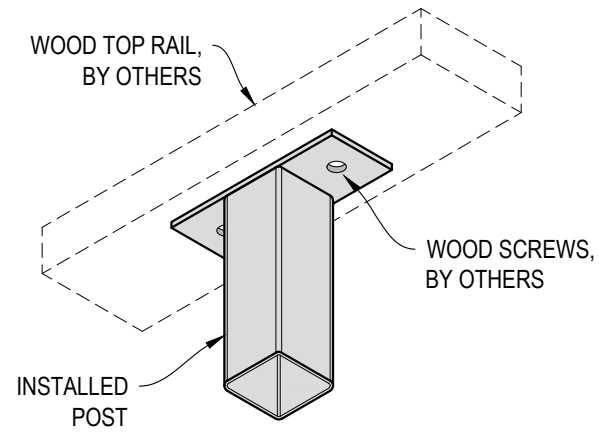

**B** TOP RAIL INSTALLATION - WOOD  
DETAIL

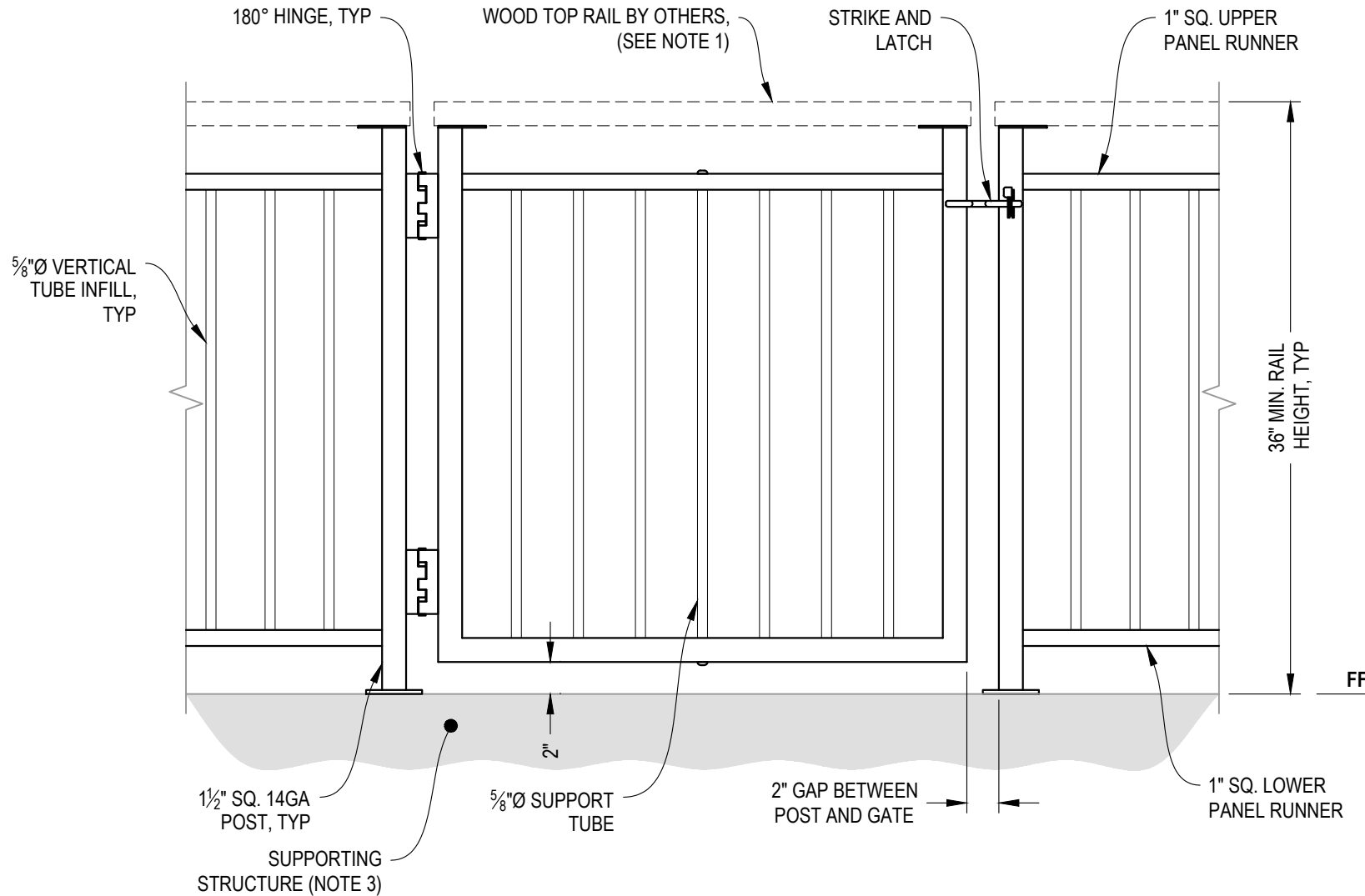

**NOTES:**

1. ALL PARTS AND COMPONENTS MADE WITH 316 STAINLESS STEEL UNLESS NOTED OTHERWISE.
2. TOP RAIL SHOULD BE SELECTED SO THAT ALL GOVERNING CODE REQUIREMENTS ARE SATISFIED. THESE INCLUDE SHAPE, STRENGTH, AND RAILING HEIGHT.
3. DECK STRUCTURE CAN VARY GREATLY. IT IS THE RESPONSIBILITY OF THE CUSTOMER TO VERIFY THAT THE SUPPORTING STRUCTURE IS ADEQUATE TO MEET THE LOAD REQUIREMENTS OF THE GOVERNING BUILDING CODE(S). *AGS Stainless Inc.* RECOMMENDS CONSULTING A DESIGN OR CONSTRUCTION PROFESSIONAL TO ADDRESS THESE ISSUES.

**A** GATE ELEVATION

AGS Stainless Clearview® Railing Systems are designed to meet the requirements of the latest edition of the IRC/IBC.

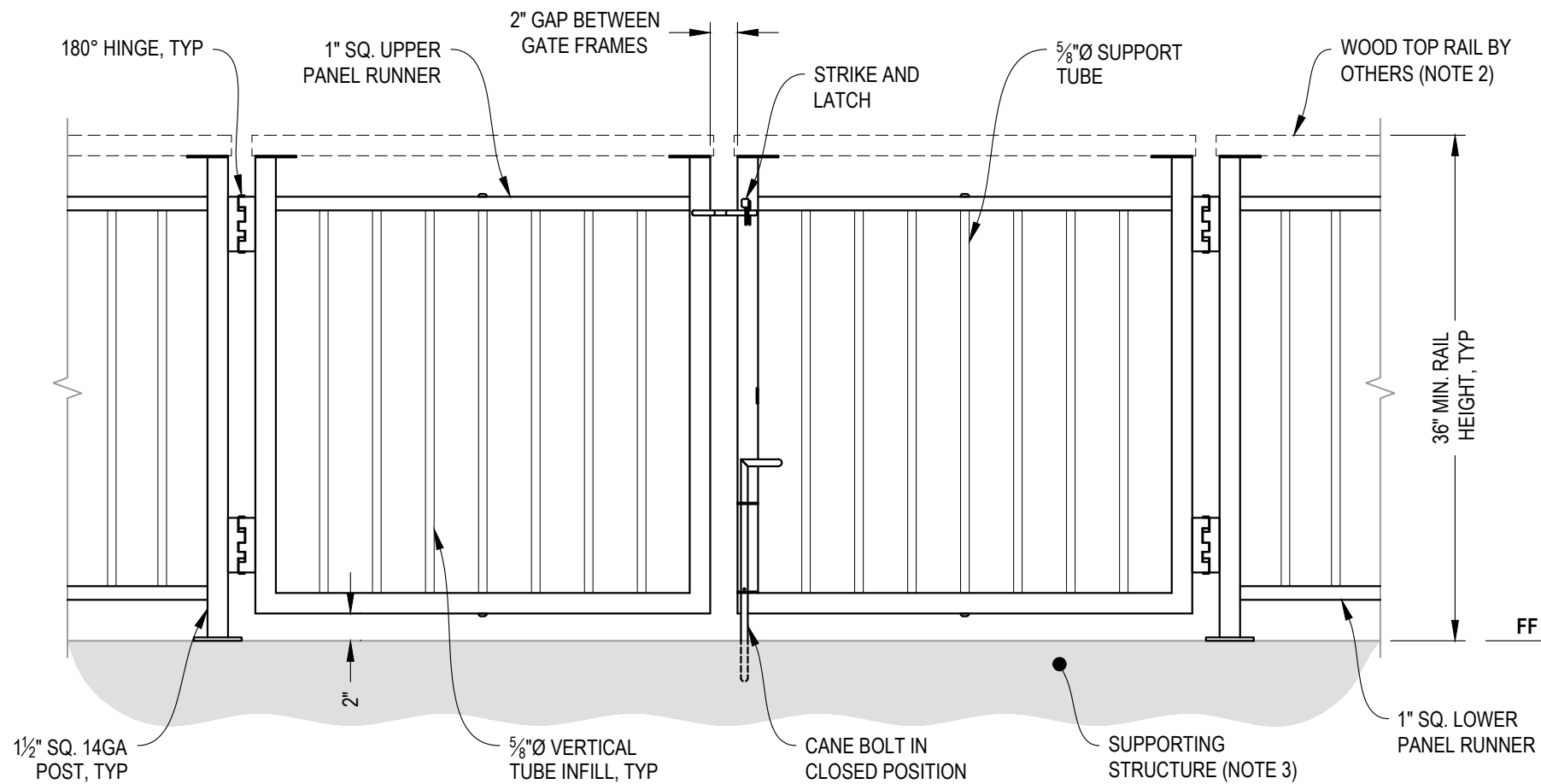

**NOTES:**

1. ALL PARTS AND COMPONENTS MADE WITH 316 STAINLESS STEEL UNLESS NOTED OTHERWISE.
2. TOP RAIL SHOULD BE SELECTED SO THAT ALL GOVERNING CODE REQUIREMENTS ARE SATISFIED. THESE INCLUDE SHAPE, STRENGTH, AND RAILING HEIGHT.
3. DECK STRUCTURE CAN VARY GREATLY. IT IS THE RESPONSIBILITY OF THE CUSTOMER TO VERIFY THAT THE SUPPORTING STRUCTURE IS ADEQUATE TO MEET THE LOAD REQUIREMENTS OF THE GOVERNING BUILDING CODE(S). AGS Stainless Inc. RECOMMENDS CONSULTING A DESIGN OR CONSTRUCTION PROFESSIONAL TO ADDRESS THESE ISSUES.

7873 NE DAY ROAD  
 BAINBRIDGE ISLAND, WA 98110  
 PHONE - (888) 842-9492  
 WWW.AGSSTAINLESS.COM



VERTICAL OLYMPUS SPECIFICATION DRAWING  
 \*\* RESIDENTIAL \*\*

36" TOP MOUNT DOUBLE GATE - WOOD TOP

**A** DOUBLE GATE  
 ELEVATION

AGS Stainless Clearview® Railing Systems are designed to meet the requirements of the latest edition of the IRC/IBC.

DWG #	TM36W
SCALE	NONE
DATE	2026
SHEET	