

**1** **EXAMPLE POST LAYOUT**  
PLAN VIEW

**NOTES:**

1. TOP RAIL NOT SHOWN FOR CLARITY.
2. ALL PARTS AND COMPONENTS MADE WITH 316 STAINLESS STEEL UNLESS NOTED OTHERWISE.

**LEGEND**

- DETAIL ID
- SHEET ID
- ELEVATION ID
- SHEET ID
- SIDE MOUNT POST
- CENTERLINE
- FF** FINISHED FLOOR
- TYP TYPICAL CONDITION APPLIES ELSEWHERE AT SIMILAR CONDITIONS

**NOTES:**

1. DECK STRUCTURE CAN VARY GREATLY. IT IS THE RESPONSIBILITY OF THE CUSTOMER TO VERIFY THAT THE SUPPORTING STRUCTURE IS ADEQUATE TO MEET THE LOAD REQUIREMENTS OF THE GOVERNING BUILDING CODE(S). *AGS Stainless Inc.* RECOMMENDS CONSULTING A DESIGN OR CONSTRUCTION PROFESSIONAL TO ADDRESS THESE ISSUES.

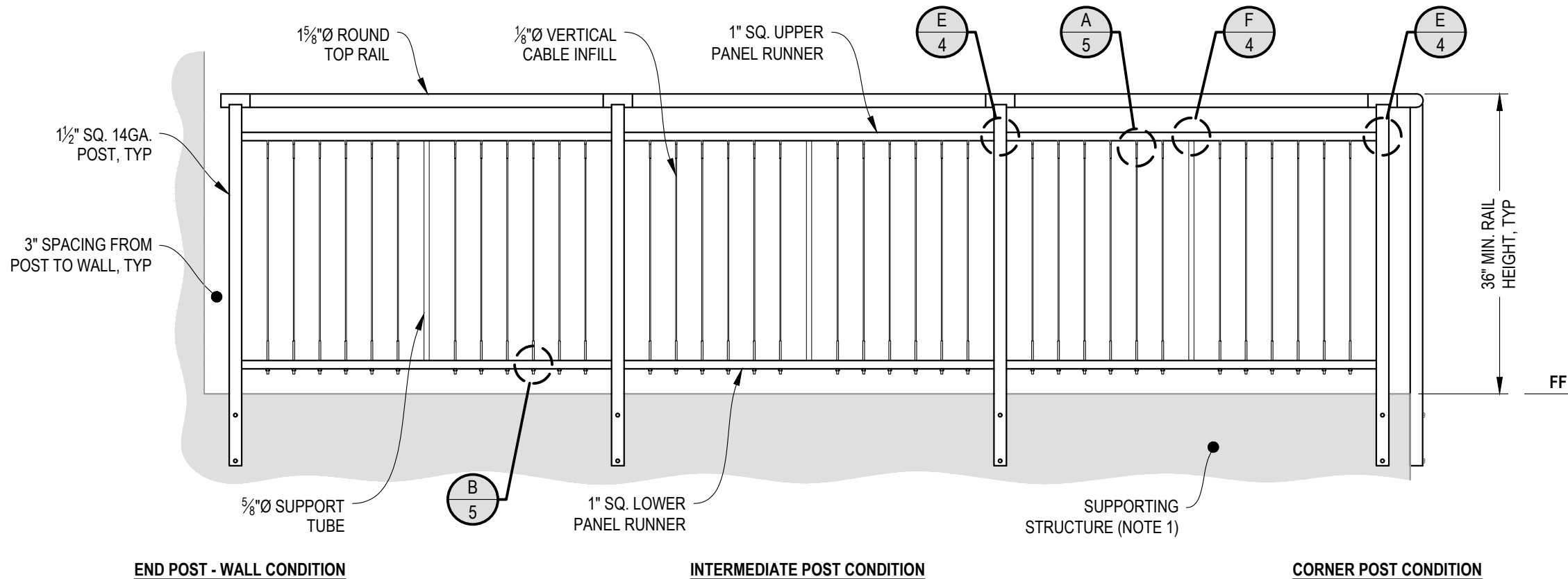

**A** **TYPICAL RAILING CONDITION**  
ELEVATION

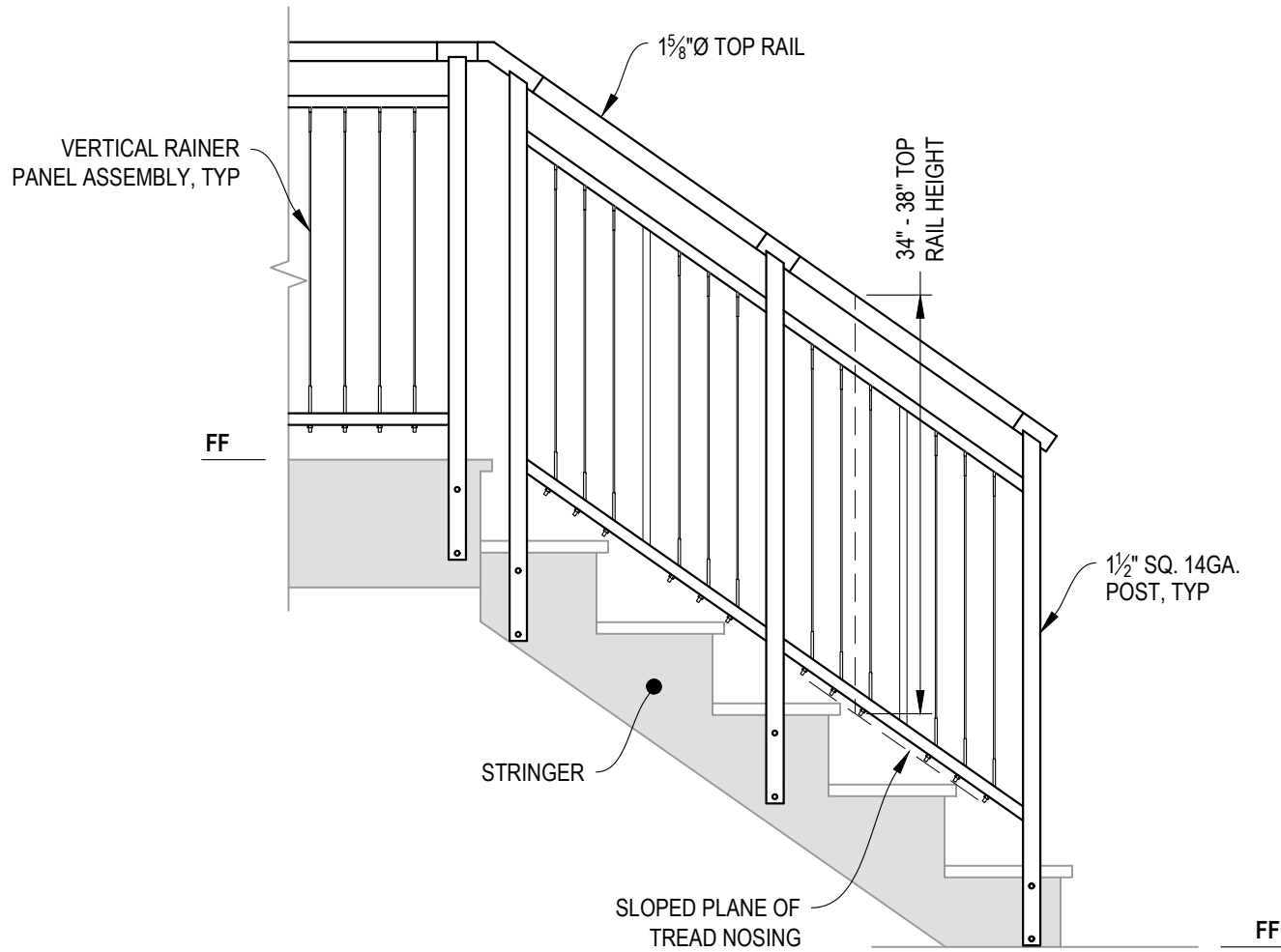

**NOTES:**

1. STAIR CONSTRUCTION VARIES GREATLY. AS-BUILT CONDITIONS MAY ALTER RAILING DESIGN, INCLUDING POST LOCATION & MOUNTING, INFILL SPACING, AND TOP RAIL LAYOUT.

**A** STAIR  
ELEVATION

AGS Stainless Clearview® Railing Systems are designed to meet the requirements of the latest edition of the IRC/IBC.

7873 NEDAY ROAD  
BAINBRIDGE ISLAND, WA 98110  
PHONE - (888) 842-9492  
WWW.AGSSTAINLESS.COM



VERTICAL RAINER SPECIFICATION DRAWING

\*\* RESIDENTIAL \*\*

36" SIDE MOUNT - ROUND TOP

DWG # SM36R

SCALE NONE

DATE 2026

SHEET

**3** OF **5**

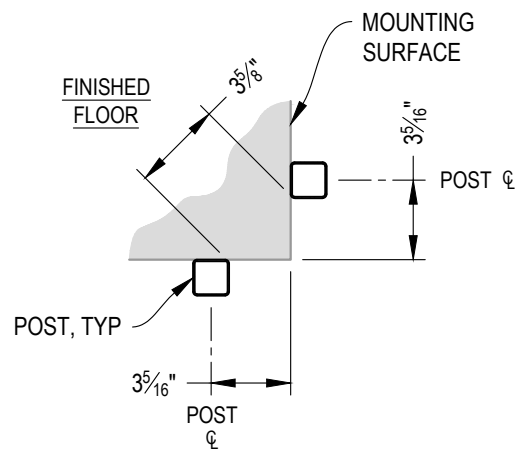

NOTE: 90° SHOWN, OTHER ANGLES SIMILAR

**A** TYPICAL 90° SIDE MOUNT OUTSIDE CORNER  
DETAIL

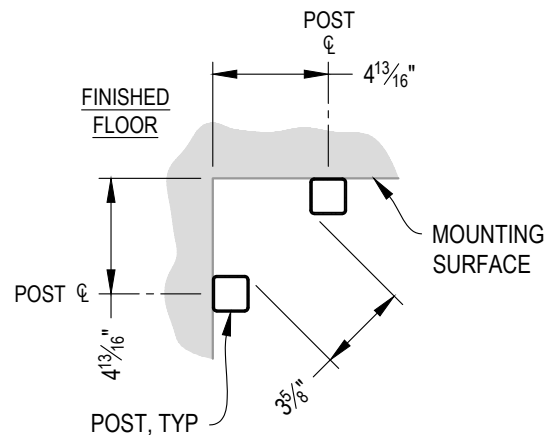

NOTE: 90° SHOWN, OTHER ANGLES SIMILAR

**B** TYPICAL 90° SIDE MOUNT INSIDE CORNER  
DETAIL

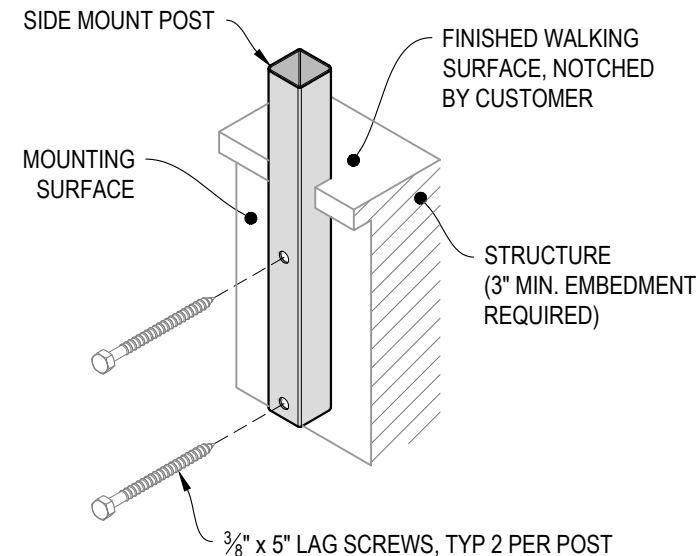

**C** TYPICAL POST MOUNTING - SIDE MOUNT  
DETAIL

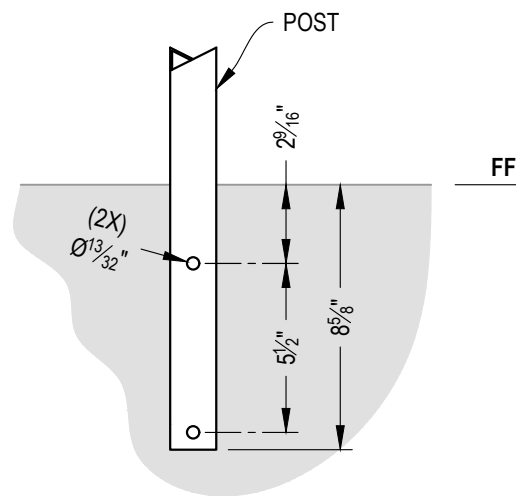

**D** TYPICAL POST MOUNTING - SIDE MOUNT  
DETAIL

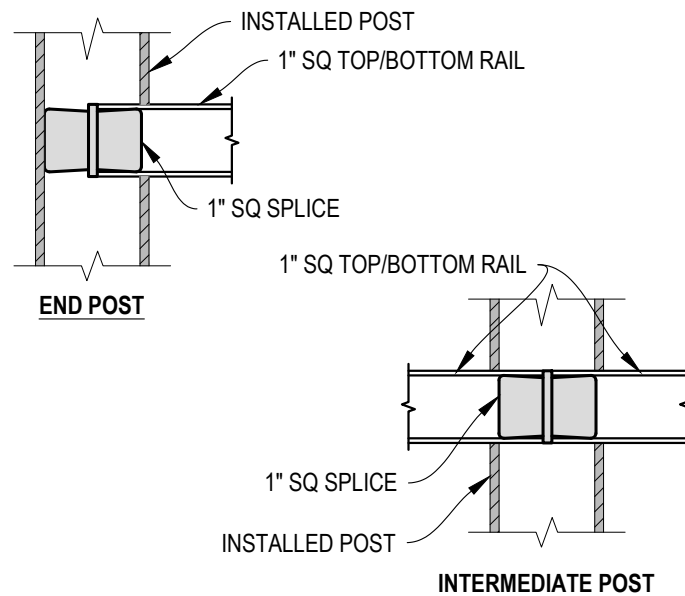

**E** FITTING INSTALLATION - VERTICAL PANEL RAIL SPLICE  
DETAIL

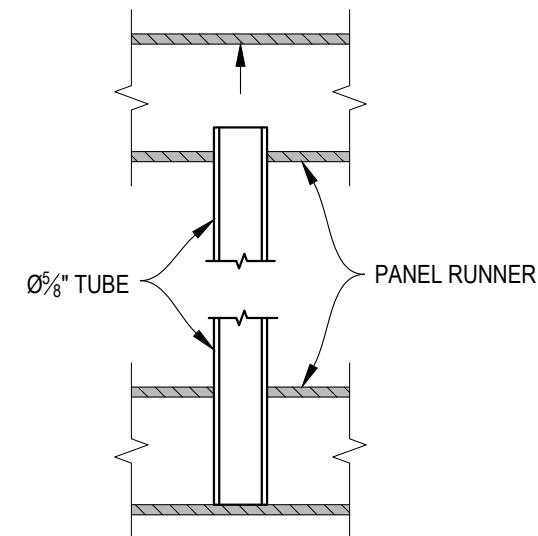

**F** PANEL SUPPORT TUBE INSTALLATION  
DETAIL

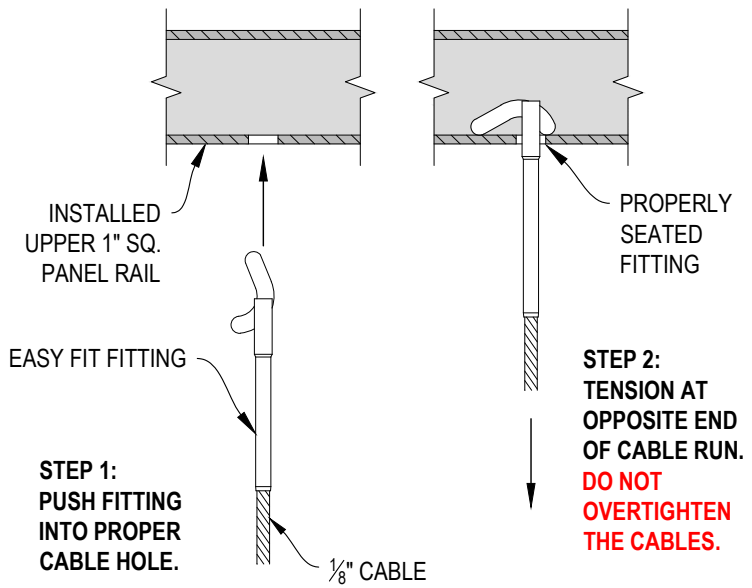

**A** FITTING INSTALLATION - EASY FIT  
DETAIL

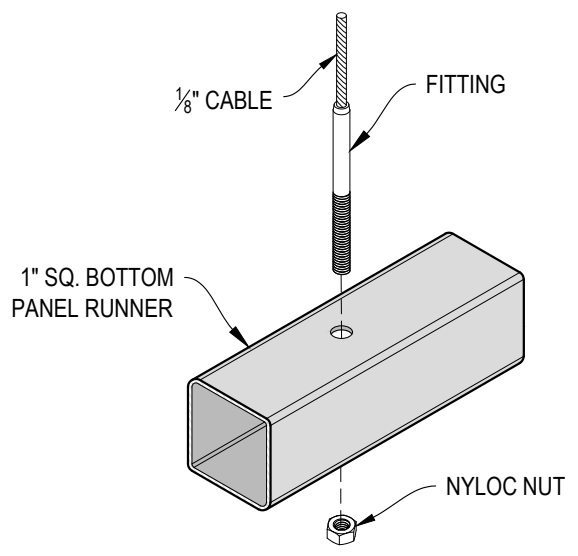

**B** FITTING INSTALLATION - STANDARD  
DETAIL

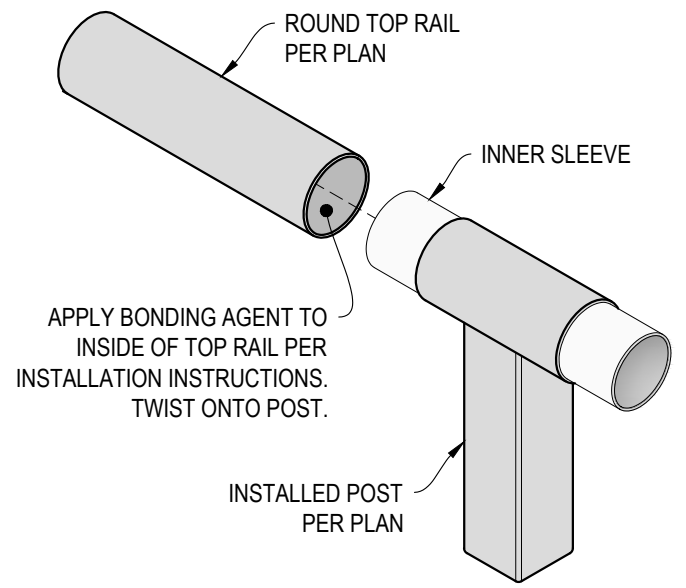

**C** TOP RAIL INSTALLATION - ROUND  
DETAIL