

1 EXAMPLE POST LAYOUT
PLAN VIEW

AGS Stainless Clearview® Railing Systems are designed to meet the requirements of the latest edition of the IRC/IBC.

NOTES:

1. TOP RAIL NOT SHOWN FOR CLARITY.
2. ALL PARTS AND COMPONENTS MADE WITH 316 STAINLESS STEEL UNLESS NOTED OTHERWISE.

LEGEND

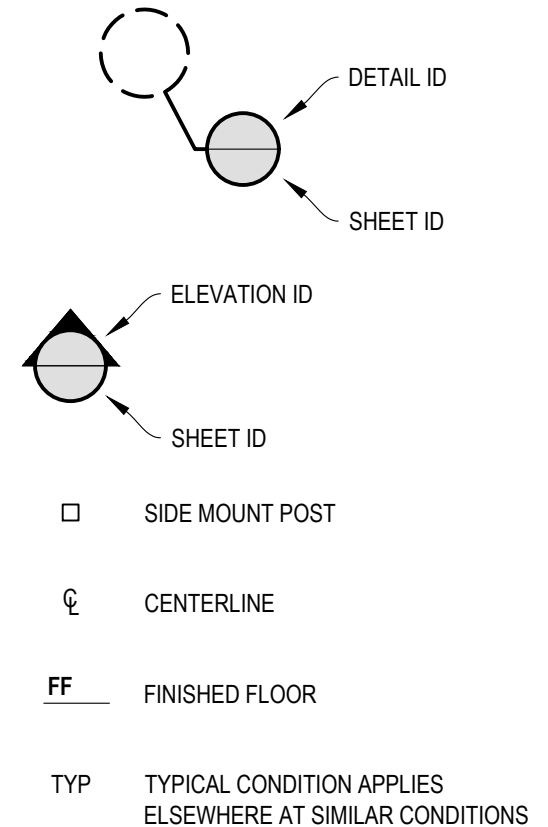

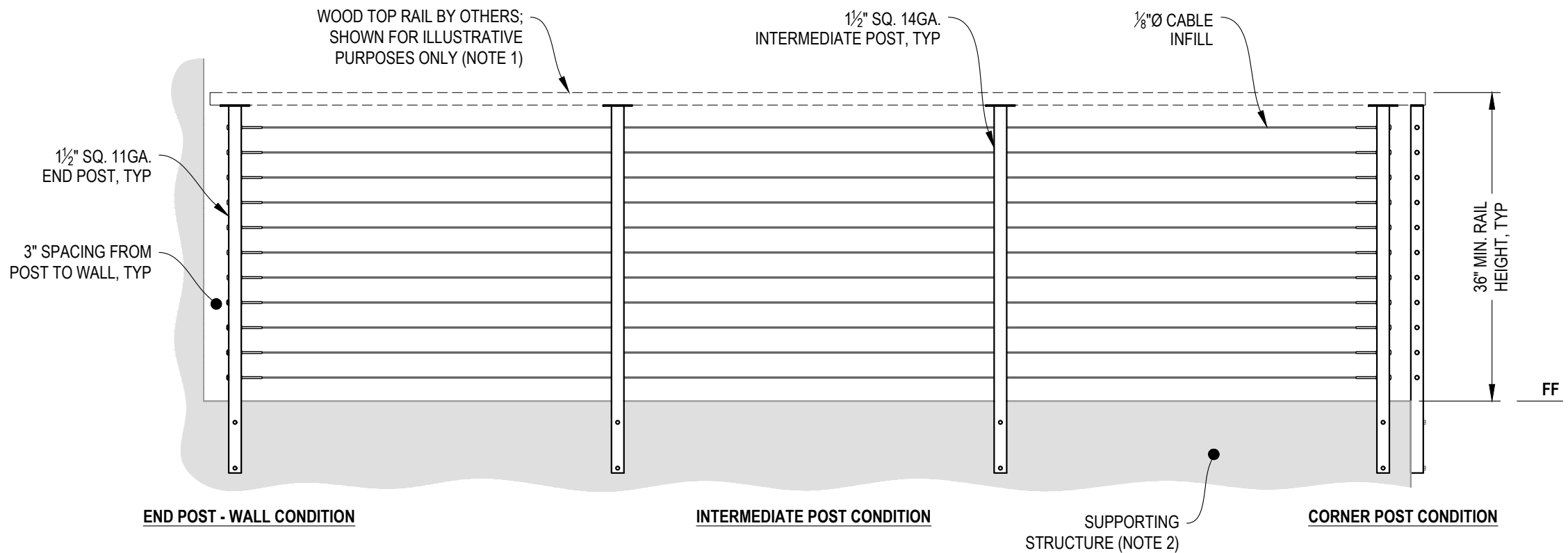

A **TYPICAL RAILING CONDITION**
ELEVATION

NOTES:

1. TOP RAIL SHOULD BE SELECTED SO THAT ALL GOVERNING CODE REQUIREMENTS ARE SATISFIED. THESE INCLUDE SHAPE, STRENGTH AND RAILING HEIGHT.
2. DECK STRUCTURE CAN VARY GREATLY. IT IS THE RESPONSIBILITY OF THE CUSTOMER TO VERIFY THAT THE SUPPORTING STRUCTURE IS ADEQUATE TO MEET THE LOAD REQUIREMENTS OF THE GOVERNING BUILDING CODE(S). AGS Stainless Inc. RECOMMENDS CONSULTING A DESIGN OR CONSTRUCTION PROFESSIONAL TO ADDRESS THESE ISSUES.

7873 NE DAY ROAD
BAINBRIDGE ISLAND, WA 98110
PHONE - (888) 842-9492
WWW.AGSSTAINLESS.COM



RAINIER SPECIFICATION DRAWING
** RESIDENTIAL **

36" SIDE MOUNT - WOOD TOP

DWG # SM36W
SCALE NONE
DATE 2026
SHEET

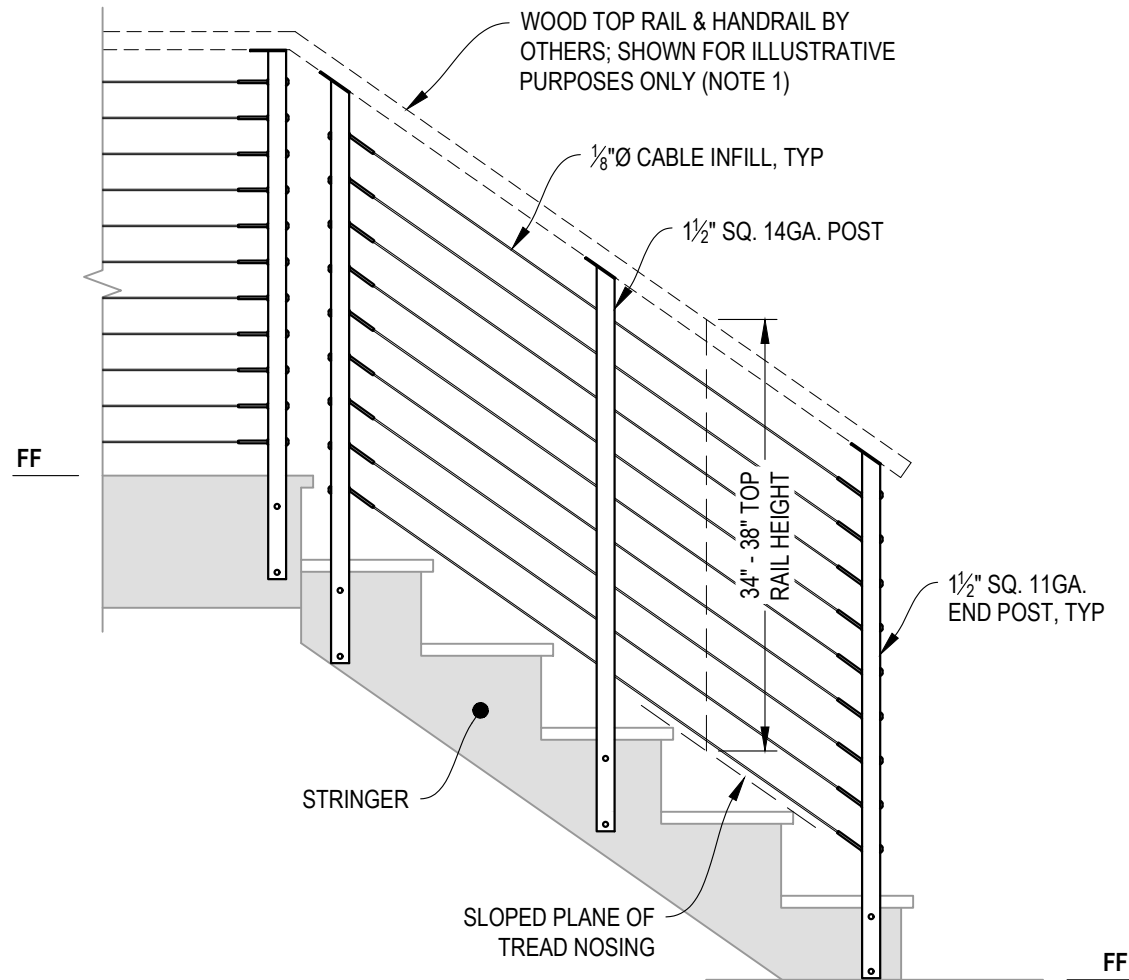

A STAIR
ELEVATION

NOTES:

1. TOP RAIL SHOULD BE SELECTED SO THAT ALL GOVERNING CODE REQUIREMENTS ARE SATISFIED. THESE INCLUDE SHAPE, STRENGTH, AND RAILING HEIGHT.
2. STAIR CONSTRUCTION VARIES GREATLY. AS-BUILT CONDITIONS MAY ALTER RAILING DESIGN, INCLUDING POST LOCATION & MOUNTING, INFILL SPACING, AND TOP RAIL LAYOUT.

7873 NE DAY ROAD
BAINBRIDGE ISLAND, WA 98110
PHONE - (888) 842-9492
WWW.AGSSTAINLESS.COM



RAINIER SPECIFICATION DRAWING
** RESIDENTIAL **

36" SIDE MOUNT - WOOD TOP

DWG # SM36W
SCALE NONE
DATE 2026
SHEET

3 OF 4

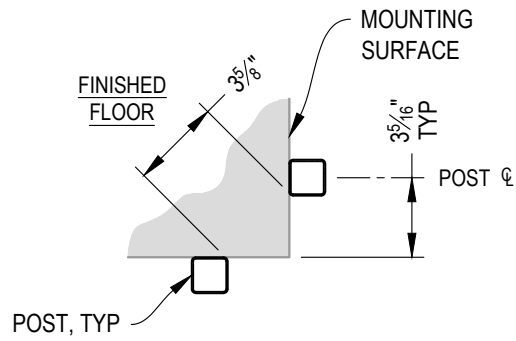

NOTE: 90° SHOWN, OTHER ANGLES SIMILAR

A TYPICAL 90° SIDE MOUNT OUTSIDE CORNER
DETAIL

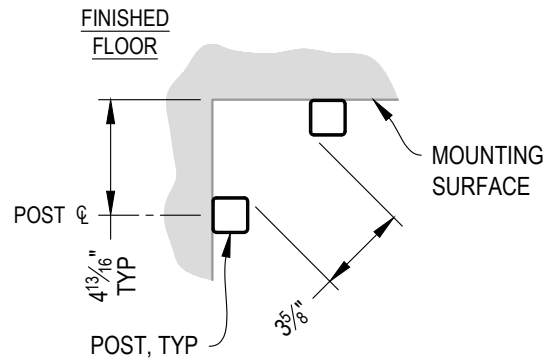

NOTE: 90° SHOWN, OTHER ANGLES SIMILAR

B TYPICAL 90° SIDE MOUNT INSIDE CORNER
DETAIL

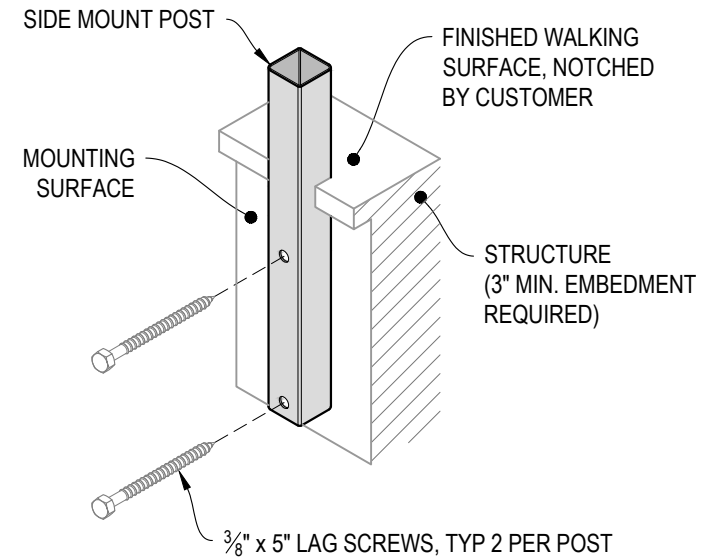

C TYPICAL POST MOUNTING - SIDE MOUNT
DETAIL

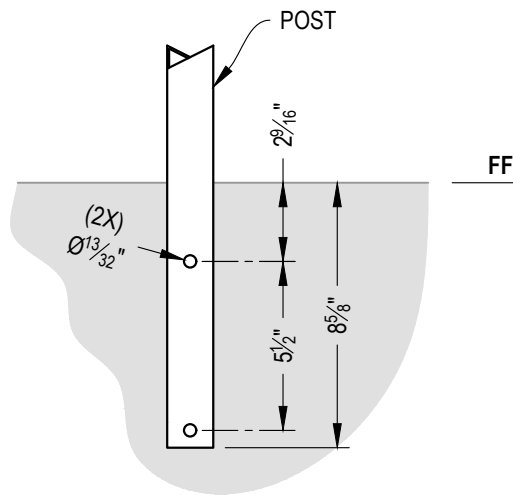

D TYPICAL POST MOUNTING - SIDE MOUNT
DETAIL

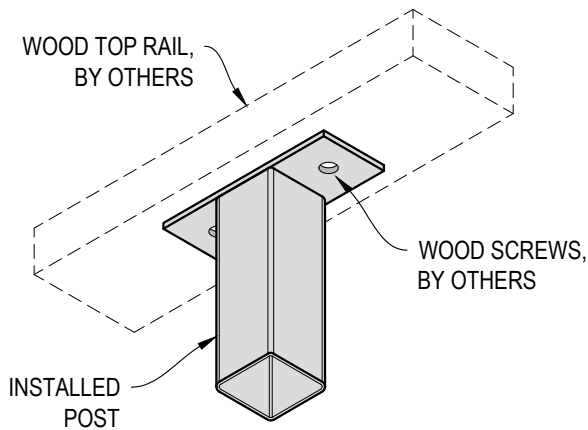

E TOP RAIL INSTALLATION - WOOD
DETAIL

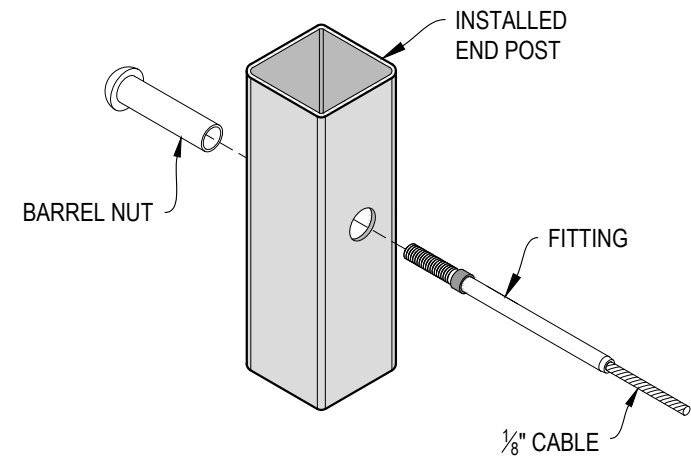

F FITTING INSTALLATION - BARREL NUT
DETAIL

7873 NEDAY ROAD
BAINBRIDGE ISLAND, WA 98110
PHONE - (888) 842-9492
WWW.AGSSTAINLESS.COM

AGS stainless
CLEARVIEW® Railing Systems

RAINIER SPECIFICATION DRAWING
** RESIDENTIAL **

36" SIDE MOUNT - WOOD TOP

DWG # SM36W
SCALE NONE
DATE 2026
SHEET

4 OF 4