

1 **EXAMPLE POST LAYOUT**
PLAN VIEW

AGS Stainless Clearview® Railing Systems are designed to meet the requirements of the latest edition of the IRC/IBC.

NOTES:

1. TOP RAIL NOT SHOWN FOR CLARITY.
2. ALL PARTS AND COMPONENTS MADE WITH 316 STAINLESS STEEL UNLESS NOTED OTHERWISE.

LEGEND

- DETAIL ID
- SHEET ID
- ELEVATION ID
- SHEET ID
- CORE DRILL POST
- CORE DRILL DOUBLE POST
- CENTERLINE
- FF** FINISHED FLOOR
- TYP TYPICAL CONDITION APPLIES ELSEWHERE AT SIMILAR CONDITIONS

7873 NE DAY ROAD
BAINBRIDGE ISLAND, WA 98110
PHONE - (888) 842-9492
WWW.AGSSTAINLESS.COM

AGS stainless
CLEARVIEW® Railing Systems

RAINIER SPECIFICATION DRAWING
** RESIDENTIAL **

42" CORE DRILL - WOOD TOP

DWG #	CD42W
SCALE	NONE
DATE	2026
SHEET	1 OF 5

NOTES:

1. TOP RAIL SHOULD BE SELECTED SO THAT ALL GOVERNING CODE REQUIREMENTS ARE SATISFIED. THESE INCLUDE SHAPE, STRENGTH AND RAILING HEIGHT.
2. DECK STRUCTURE CAN VARY GREATLY. IT IS THE RESPONSIBILITY OF THE CUSTOMER TO VERIFY THAT THE SUPPORTING STRUCTURE IS ADEQUATE TO MEET THE LOAD REQUIREMENTS OF THE GOVERNING BUILDING CODE(S). AGS Stainless Inc. RECOMMENDS CONSULTING A DESIGN OR CONSTRUCTION PROFESSIONAL TO ADDRESS THESE ISSUES.

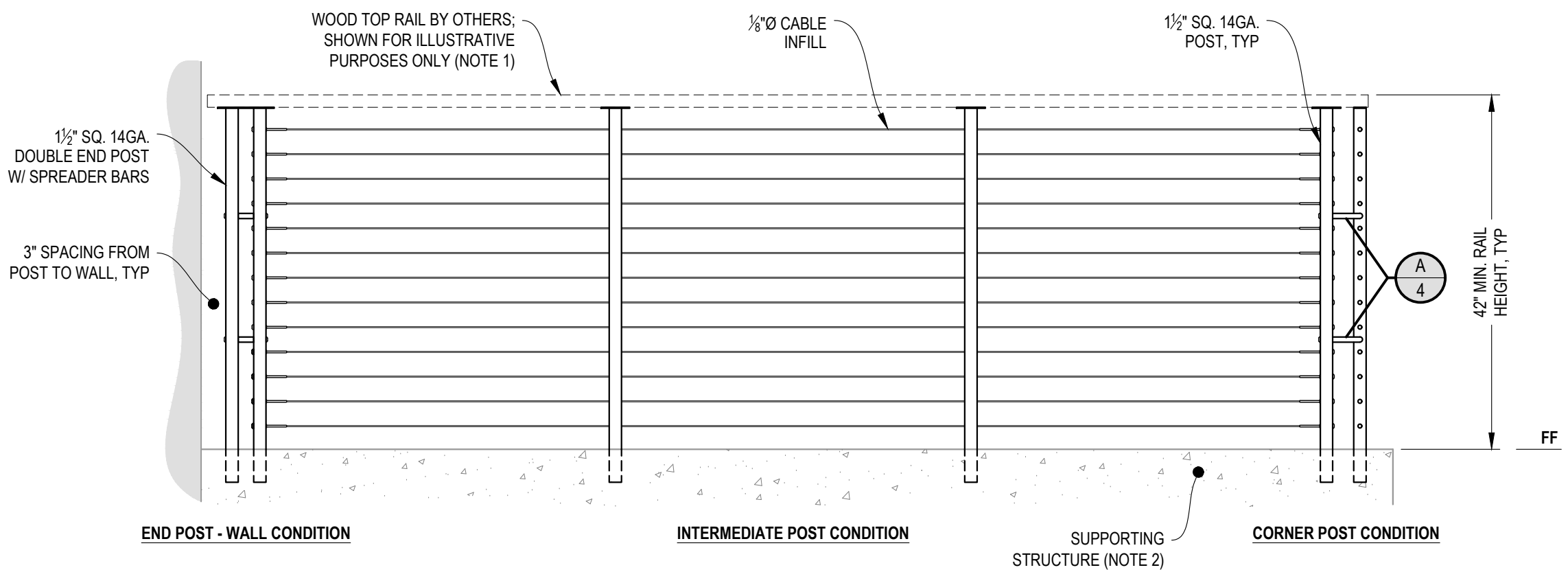

A **TYPICAL RAILING CONDITION**
 ELEVATION

RAINIER SPECIFICATION DRAWING
 ** RESIDENTIAL **
 42" CORE DRILL - WOOD TOP

DWG #	CD42W
SCALE	NONE
DATE	2026
SHEET	

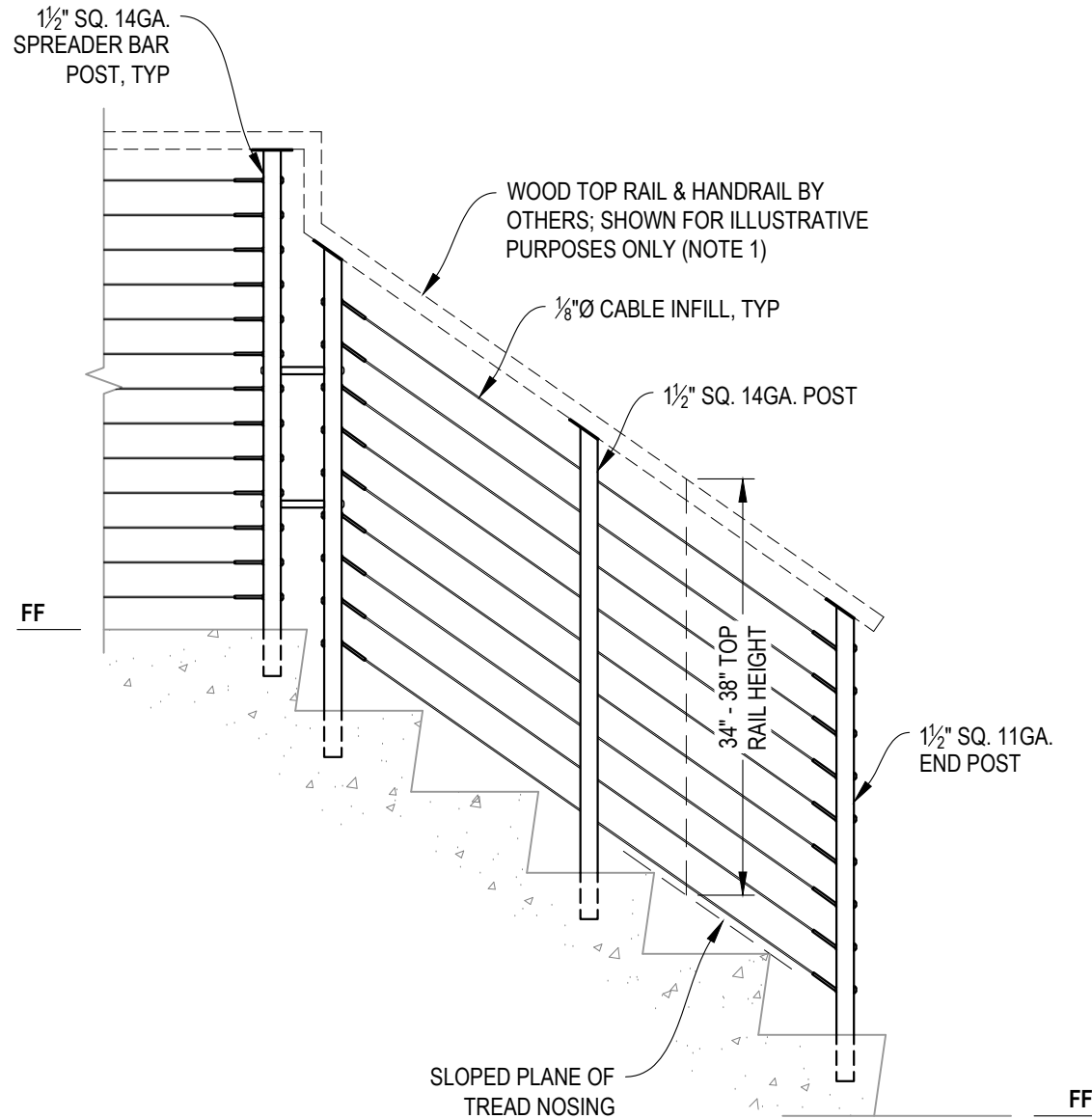

A STAIR
ELEVATION

NOTES:

1. TOP RAIL SHOULD BE SELECTED SO THAT ALL GOVERNING CODE REQUIREMENTS ARE SATISFIED. THESE INCLUDE SHAPE, STRENGTH, AND RAILING HEIGHT.
2. STAIR CONSTRUCTION VARIES GREATLY. AS-BUILT CONDITIONS MAY ALTER RAILING DESIGN, INCLUDING POST LOCATION & MOUNTING, INFILL SPACING, AND TOP RAIL LAYOUT.

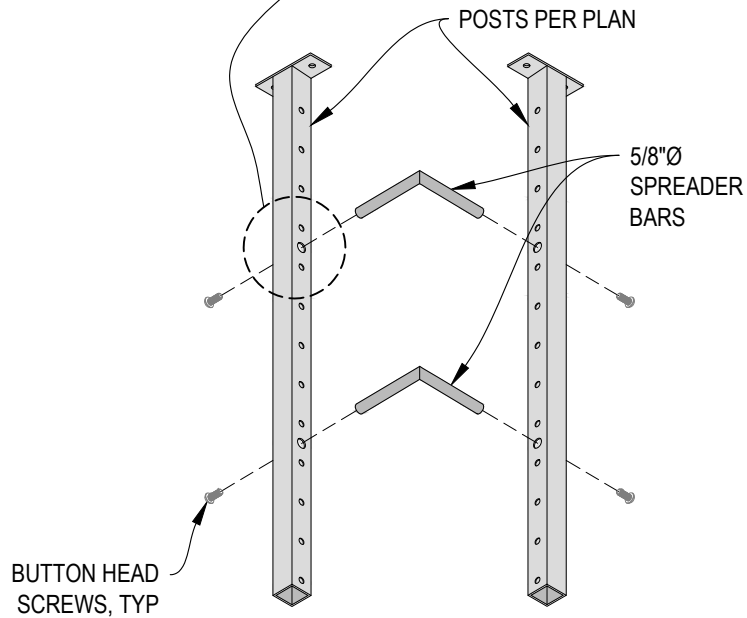
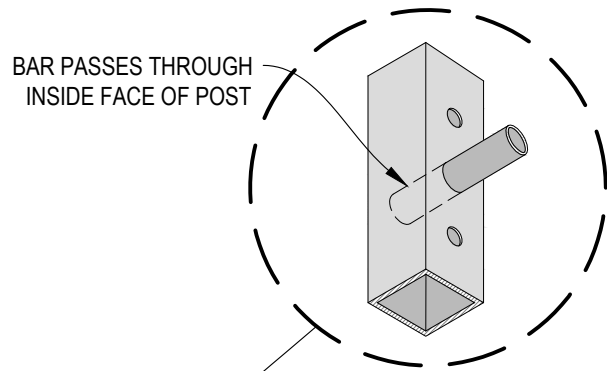

A CORNER POST ASSEMBLY
DETAIL

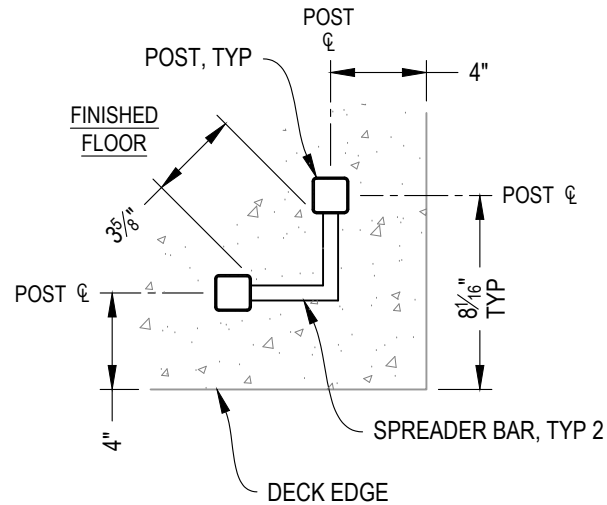

NOTE: 90° SHOWN, OTHER ANGLES SIMILAR

B TYPICAL 90° TOP MOUNT OUTSIDE CORNER
DETAIL

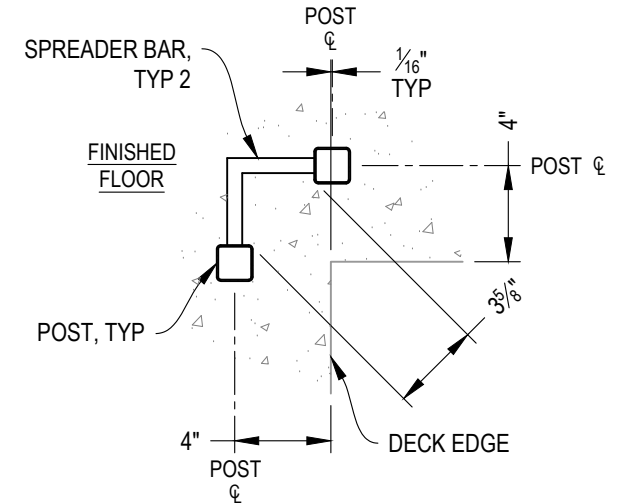

NOTE: 90° SHOWN, OTHER ANGLES SIMILAR

C TYPICAL 90° TOP MOUNT INSIDE CORNER
DETAIL

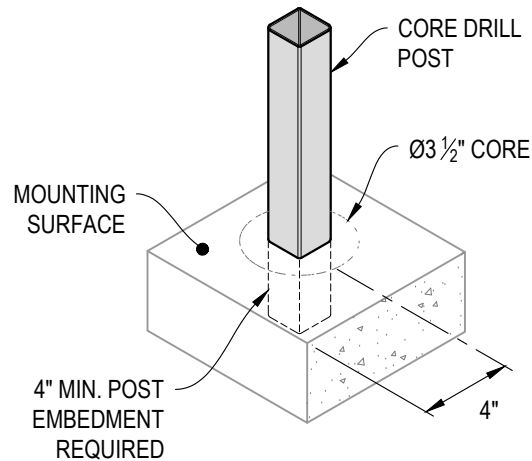

D TYPICAL POST MOUNTING - CORE DRILL
DETAIL

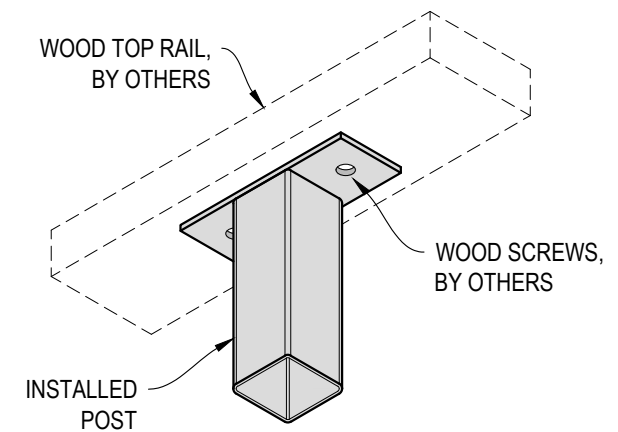

E TOP RAIL INSTALLATION - WOOD
DETAIL

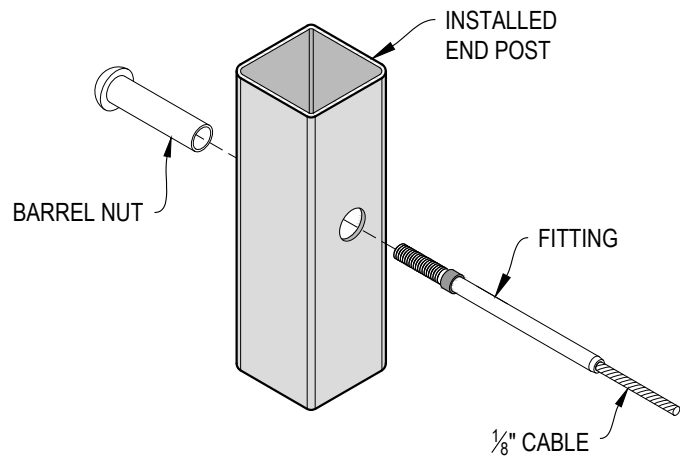

A FITTING INSTALLATION - BARREL NUT
DETAIL

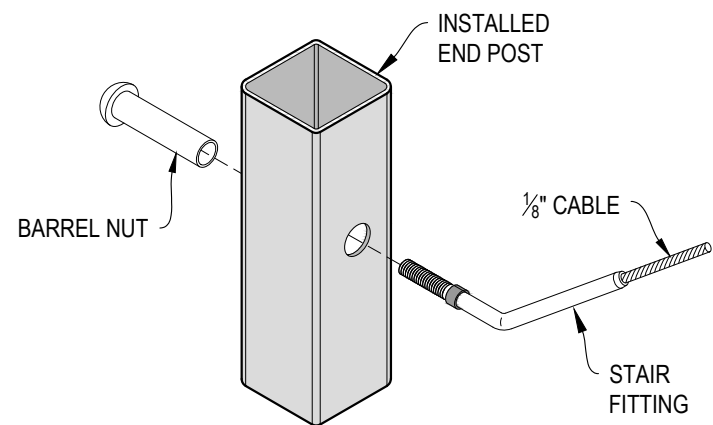

B FITTING INSTALLATION - STAIR
DETAIL

RAINIER SPECIFICATION DRAWING
** RESIDENTIAL **

42" CORE DRILL - WOOD TOP

DWG # CD42W
SCALE NONE
DATE 2026
SHEET

5
OF 5



7873 NEDAY ROAD
BAINBRIDGE ISLAND, WA 98110
PHONE - (888) 842-9492
WWW.AGSSTAINLESS.COM