

1 EXAMPLE POST LAYOUT
PLAN VIEW

AGS Stainless Clearview® Railing Systems are designed to meet the requirements of the latest edition of the IRC/IBC.

NOTES:

1. TOP RAIL NOT SHOWN FOR CLARITY.
2. ALL PARTS AND COMPONENTS MADE WITH 316 STAINLESS STEEL UNLESS NOTED OTHERWISE.

LEGEND

- DETAIL ID
- SHEET ID
- ELEVATION ID
- SHEET ID
- CORE DRILL POST
- CENTERLINE
- FF** FINISHED FLOOR
- TYP TYPICAL CONDITION APPLIES ELSEWHERE AT SIMILAR CONDITIONS

7873 NEDAY ROAD
BAINBRIDGE ISLAND, WA 98110
PHONE - (888) 842-9492
WWW.AGSSTAINLESS.COM

AGS stainless
CLEARVIEW® Railing Systems

RAINIER SPECIFICATION DRAWING
** RESIDENTIAL **

36" CORE DRILL - FLAT TOP

DWG #	CD36F
SCALE	NONE
DATE	2026
SHEET	1 OF 4

NOTES:

1. DECK STRUCTURE CAN VARY GREATLY. IT IS THE RESPONSIBILITY OF THE CUSTOMER TO VERIFY THAT THE SUPPORTING STRUCTURE IS ADEQUATE TO MEET THE LOAD REQUIREMENTS OF THE GOVERNING BUILDING CODE(S). *AGS Stainless Inc.* RECOMMENDS CONSULTING A DESIGN OR CONSTRUCTION PROFESSIONAL TO ADDRESS THESE ISSUES.

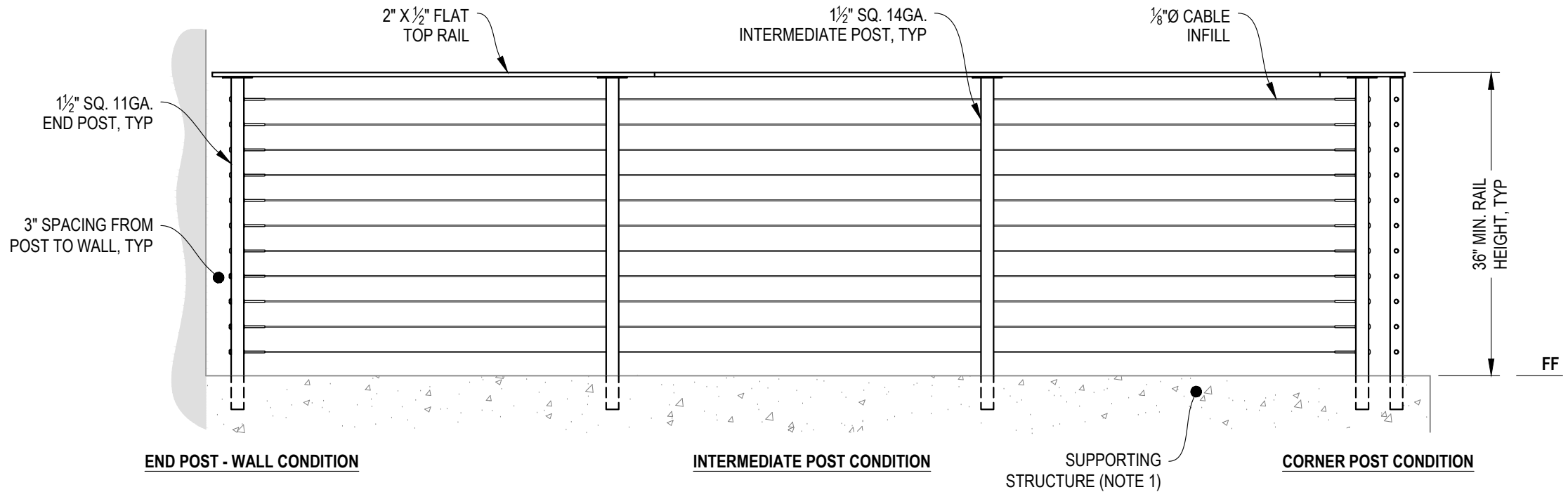

A TYPICAL RAILING CONDITION
ELEVATION

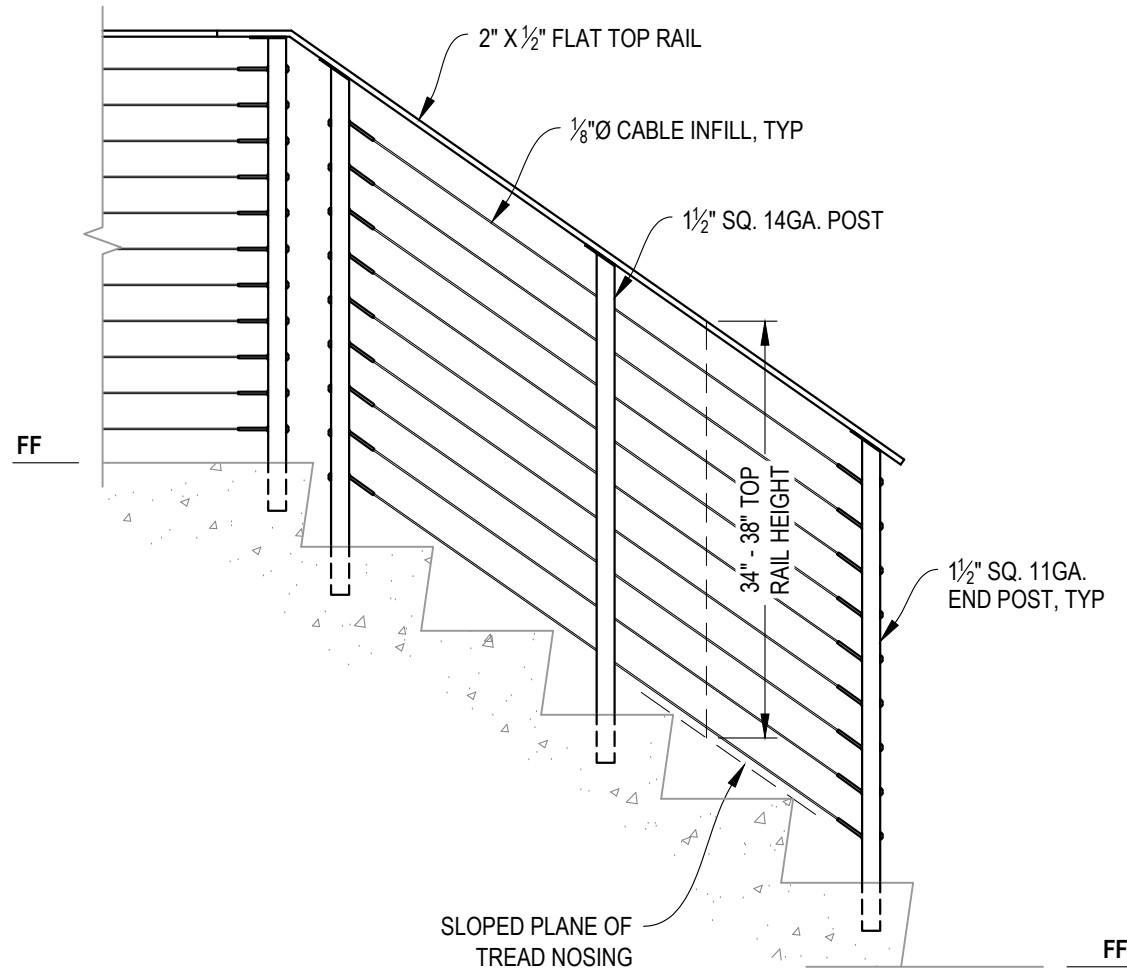

A STAIR
ELEVATION

NOTES:

1. STAIR CONSTRUCTION VARIES GREATLY. AS-BUILT CONDITIONS MAY ALTER RAILING DESIGN, INCLUDING POST LOCATION & MOUNTING, INFILL SPACING, AND TOP RAIL LAYOUT.

7873 NEDAY ROAD
BAINBRIDGE ISLAND, WA 98110
PHONE - (888) 842-9492
WWW.AGSSTAINLESS.COM



RAINIER SPECIFICATION DRAWING
** RESIDENTIAL **
36" CORE DRILL - FLAT TOP

DWG #	CD36F
SCALE	NONE
DATE	2026
SHEET	

3 OF 4

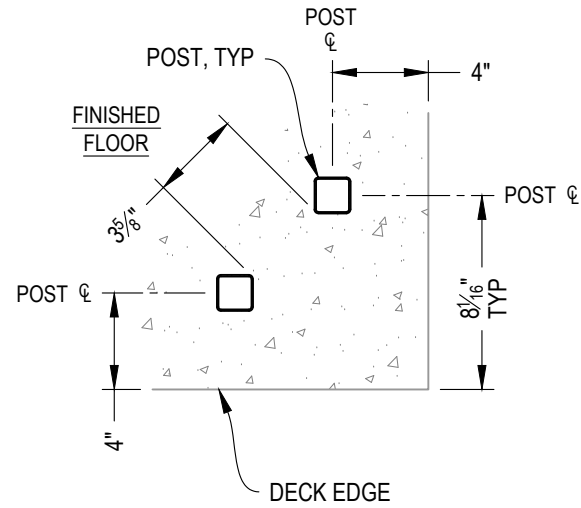

NOTE: 90° SHOWN, OTHER ANGLES SIMILAR

A TYPICAL 90° TOP MOUNT OUTSIDE CORNER
DETAIL

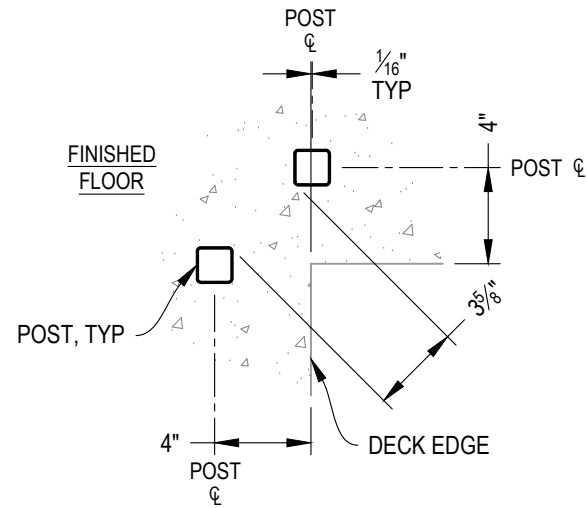

NOTE: 90° SHOWN, OTHER ANGLES SIMILAR

B TYPICAL 90° TOP MOUNT INSIDE CORNER
DETAIL

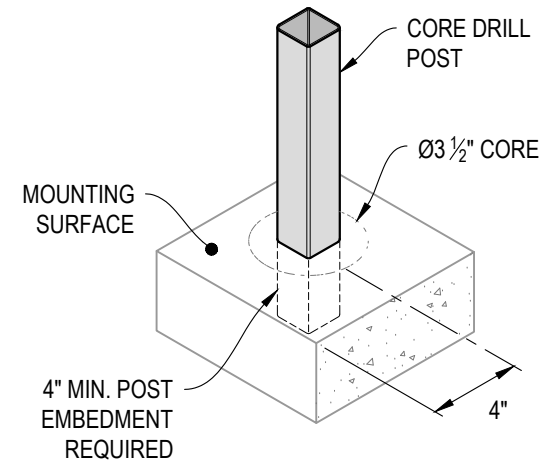

C TYPICAL POST MOUNTING - CORE DRILL
DETAIL

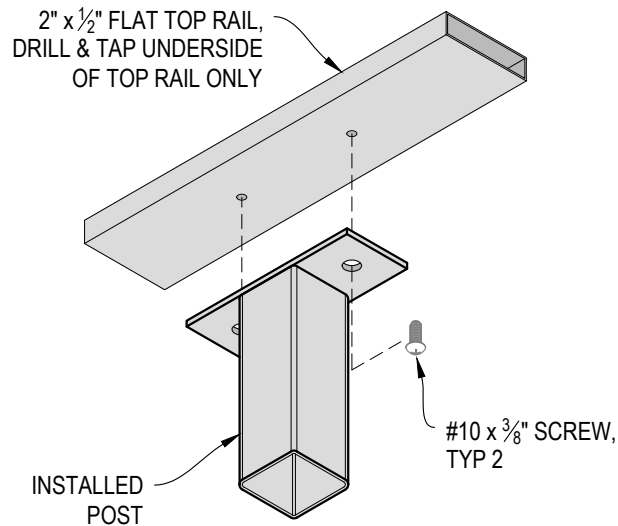

D TOP RAIL INSTALLATION - FLAT
DETAIL

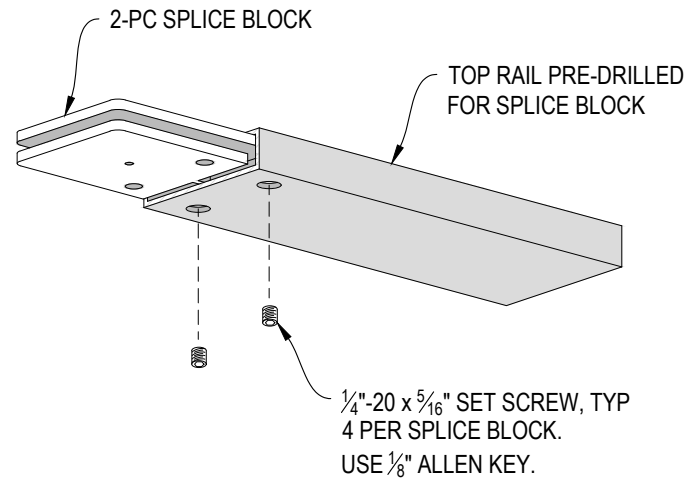

E SPLICE BLOCK ASSEMBLY - FLAT
DETAIL

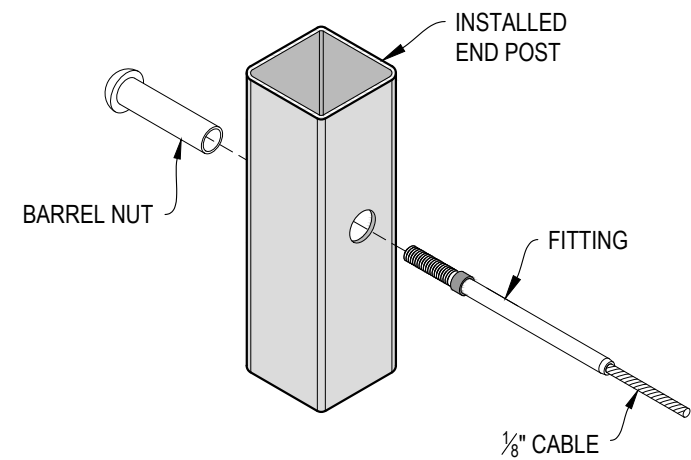

F FITTING INSTALLATION - BARREL NUT
DETAIL