

**1** EXAMPLE POST LAYOUT  
PLAN VIEW

AGS Stainless Clearview® Railing Systems are designed to meet the requirements of the latest edition of the IRC/IBC.

**NOTES:**

1. TOP RAIL NOT SHOWN FOR CLARITY.
2. ALL PARTS AND COMPONENTS MADE WITH 316 STAINLESS STEEL UNLESS NOTED OTHERWISE.

**LEGEND**

- DETAIL ID
- SHEET ID
- ELEVATION ID
- SHEET ID
- SIDE MOUNT POST
- SIDE MOUNT DOUBLE POST
- CENTERLINE
- FINISHED FLOOR
- TYP TYPICAL CONDITION APPLIES ELSEWHERE AT SIMILAR CONDITIONS

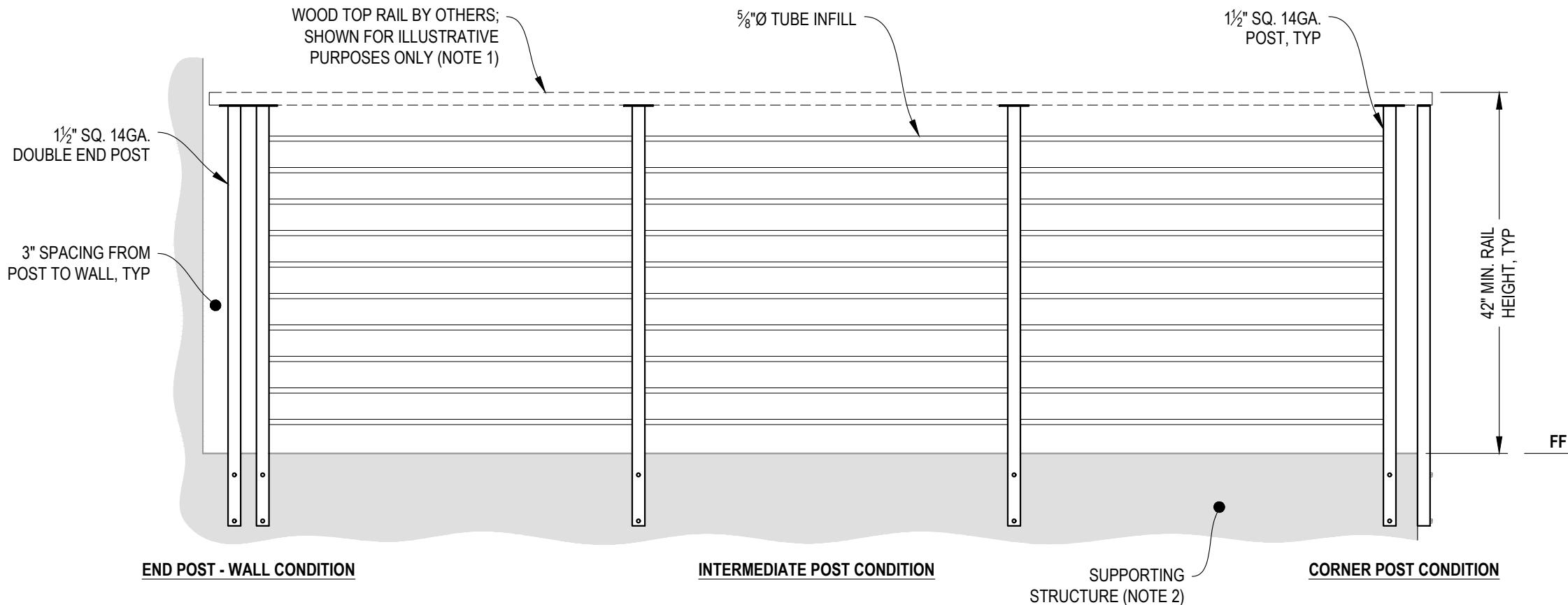

**A** **TYPICAL RAILING CONDITION**  
ELEVATION

**NOTES:**

1. TOP RAIL SHOULD BE SELECTED SO THAT ALL GOVERNING CODE REQUIREMENTS ARE SATISFIED. THESE INCLUDE SHAPE, STRENGTH AND RAILING HEIGHT.
2. DECK STRUCTURE CAN VARY GREATLY. IT IS THE RESPONSIBILITY OF THE CUSTOMER TO VERIFY THAT THE SUPPORTING STRUCTURE IS ADEQUATE TO MEET THE LOAD REQUIREMENTS OF THE GOVERNING BUILDING CODE(S). *AGS Stainless Inc.* RECOMMENDS CONSULTING A DESIGN OR CONSTRUCTION PROFESSIONAL TO ADDRESS THESE ISSUES.

7873 NEDAY ROAD  
BAINBRIDGE ISLAND, WA 98110  
PHONE - (888) 842-9492  
WWW.AGSSTAINLESS.COM



OLYMPUS SPECIFICATION DRAWING  
\*\* RESIDENTIAL \*\*

42" SIDE MOUNT - WOOD TOP

DWG # SM42W  
SCALE NONE  
DATE 2026  
SHEET

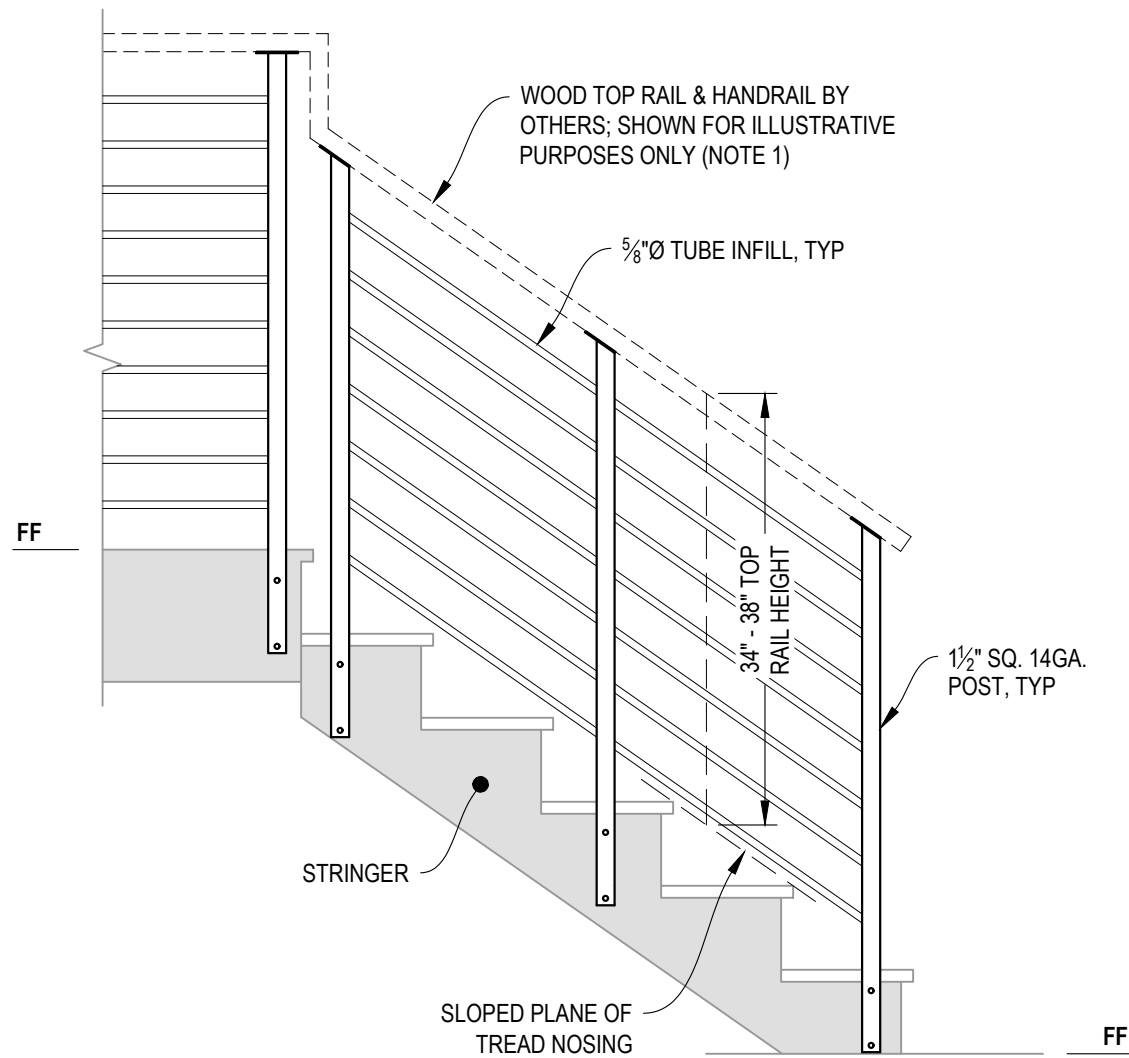

**A** STAIR  
ELEVATION

**NOTES:**

1. TOP RAIL SHOULD BE SELECTED SO THAT ALL GOVERNING CODE REQUIREMENTS ARE SATISFIED. THESE INCLUDE SHAPE, STRENGTH, AND RAILING HEIGHT.
2. STAIR CONSTRUCTION VARIES GREATLY. AS-BUILT CONDITIONS MAY ALTER RAILING DESIGN, INCLUDING POST LOCATION & MOUNTING, INFILL SPACING, AND TOP RAIL LAYOUT.

7873 NE DAY ROAD  
BAINBRIDGE ISLAND, WA 98110  
PHONE - (888) 842-9492  
WWW.AGSSTAINLESS.COM



OLYMPUS SPECIFICATION DRAWING  
\*\* RESIDENTIAL \*\*

42" SIDE MOUNT - WOOD TOP

DWG # SM42W

SCALE NONE

DATE 2026

SHEET

**3** OF 4

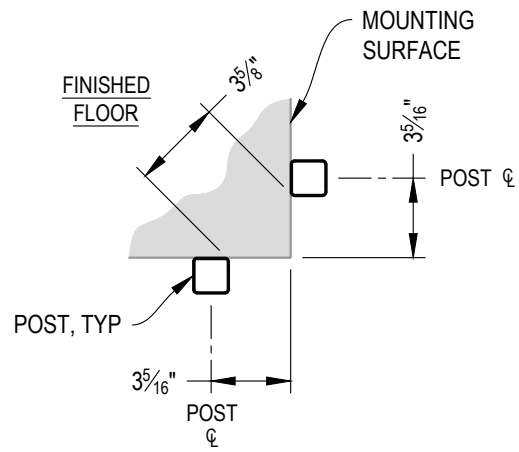

**A** TYPICAL 90° SIDE MOUNT OUTSIDE CORNER  
DETAIL

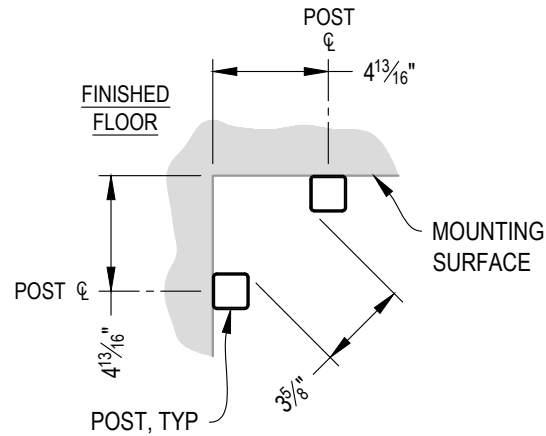

**B** TYPICAL 90° SIDE MOUNT INSIDE CORNER  
DETAIL

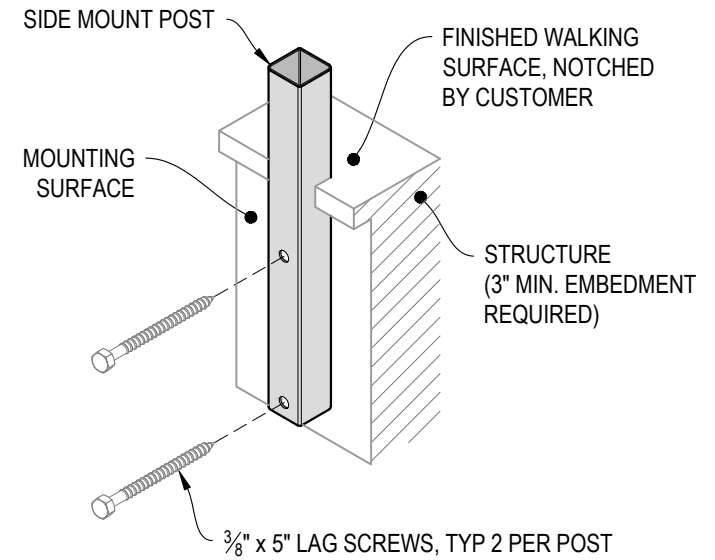

**C** TYPICAL POST MOUNTING - SIDE MOUNT  
DETAIL

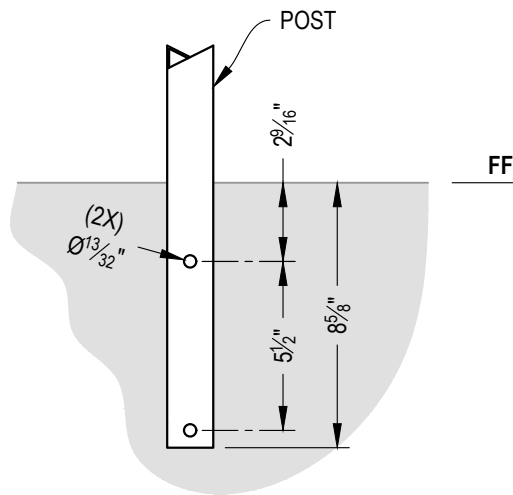

**D** TYPICAL POST MOUNTING - SIDE MOUNT  
DETAIL

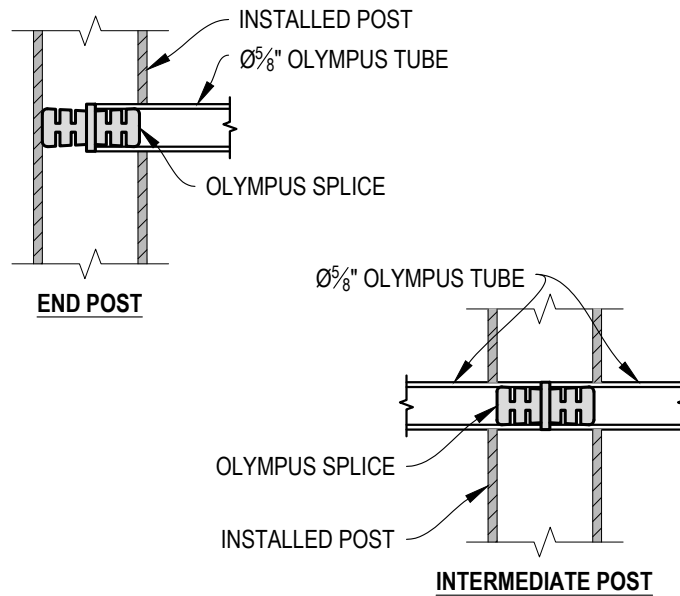

**E** FITTING INSTALLATION - OLYMPUS SPLICE  
DETAIL

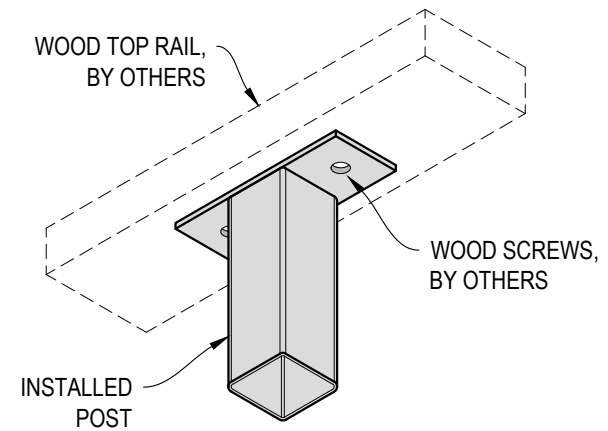

**F** TOP RAIL INSTALLATION - WOOD  
DETAIL