

1 EXAMPLE POST LAYOUT
PLAN VIEW

NOTES:

1. TOP RAIL NOT SHOWN FOR CLARITY.
2. ALL PARTS AND COMPONENTS MADE WITH 316 STAINLESS STEEL UNLESS NOTED OTHERWISE.

LEGEND

- DETAIL ID
- SHEET ID
- ELEVATION ID
- SHEET ID
- SIDE MOUNT POST
- SIDE MOUNT DOUBLE POST
- CENTERLINE
- FINISHED FLOOR
- TYP TYPICAL CONDITION APPLIES ELSEWHERE AT SIMILAR CONDITIONS

NOTES:

1. TOP RAIL SHOULD BE SELECTED SO THAT ALL GOVERNING CODE REQUIREMENTS ARE SATISFIED. THESE INCLUDE SHAPE, STRENGTH AND RAILING HEIGHT.
2. DECK STRUCTURE CAN VARY GREATLY. IT IS THE RESPONSIBILITY OF THE CUSTOMER TO VERIFY THAT THE SUPPORTING STRUCTURE IS ADEQUATE TO MEET THE LOAD REQUIREMENTS OF THE GOVERNING BUILDING CODE(S). AGS Stainless Inc. RECOMMENDS CONSULTING A DESIGN OR CONSTRUCTION PROFESSIONAL TO ADDRESS THESE ISSUES.

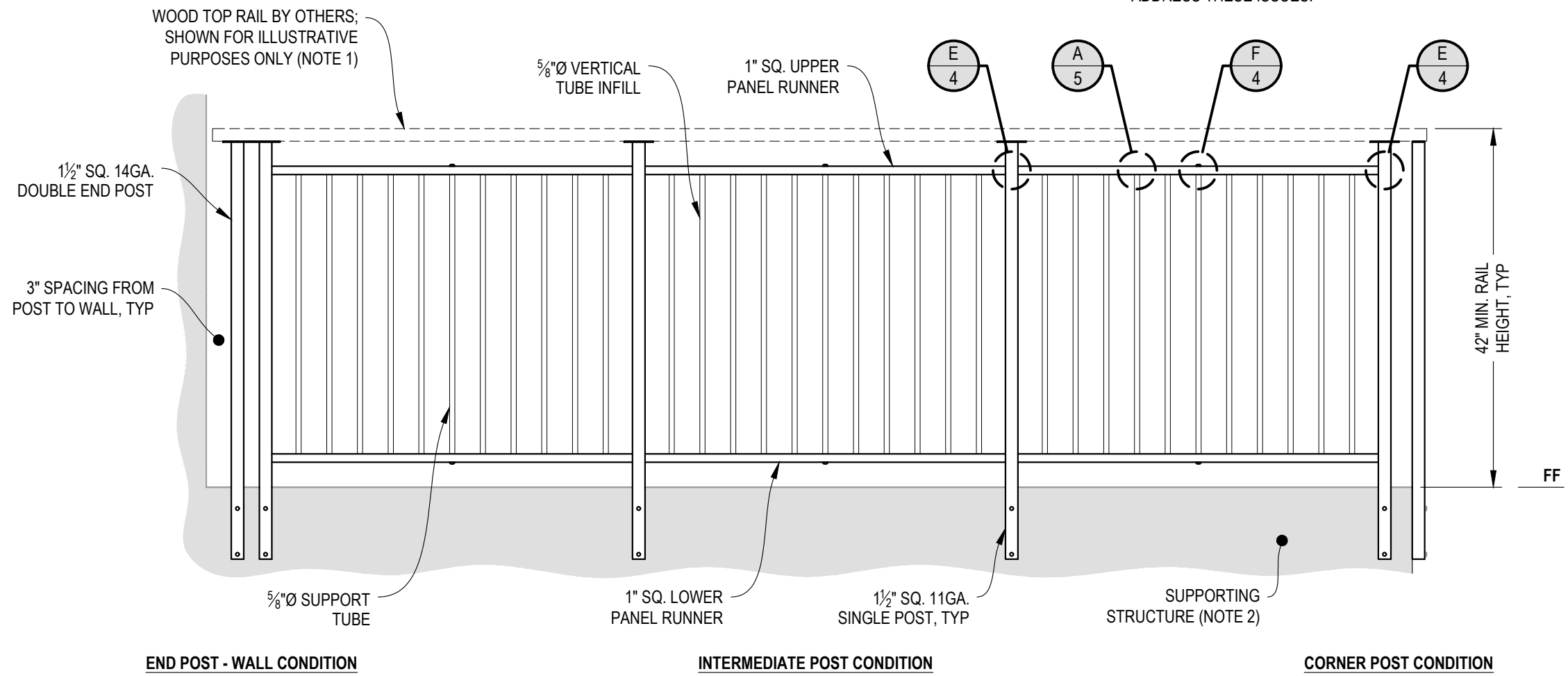

A **TYPICAL RAILING CONDITION**
 ELEVATION

VERTICAL OLYMPUS SPECIFICATION DRAWING
 ** COMMERCIAL **

42" SIDE MOUNT - WOOD TOP

DWG #	SM42WC
SCALE	NONE
DATE	2026
SHEET	

WOOD TOP RAIL & HANDRAIL BY OTHERS; SHOWN FOR ILLUSTRATIVE PURPOSES ONLY (NOTE 1)

HANDRAIL POST BRACKET, TYP

42" MIN. TOP RAIL HEIGHT

1 1/2" SQ. 11GA. SINGLE POST, TYP

34" - 38" HANDRAIL HEIGHT

1 1/2" SQ. 14GA. DOUBLE END POST

VERTICAL OLYMPUS PANEL ASSEMBLY, TYP

FF

12" HANDRAIL EXTENSION

STRINGER

SLOPED PLANE OF TREAD NOSING, TYP

FF

ONE TREAD LENGTH MIN.

A STAIR ELEVATION

NOTES:

1. TOP RAIL SHOULD BE SELECTED SO THAT ALL GOVERNING CODE REQUIREMENTS ARE SATISFIED. THESE INCLUDE SHAPE, STRENGTH, AND RAILING HEIGHT.
2. STAIR CONSTRUCTION VARIES GREATLY. AS-BUILT CONDITIONS MAY ALTER RAILING DESIGN, INCLUDING POST LOCATION & MOUNTING, INFILL SPACING, AND TOP RAIL LAYOUT.

7873 NE DAY ROAD
BAINBRIDGE ISLAND, WA 98110
PHONE - (888) 842-9492
WWW.AGSSTAINLESS.COM



VERTICAL OLYMPUS SPECIFICATION DRAWING

** COMMERCIAL **

42" SIDE MOUNT - WOOD TOP

DWG # SM42WC

SCALE NONE

DATE 2026

SHEET

3 OF **5**

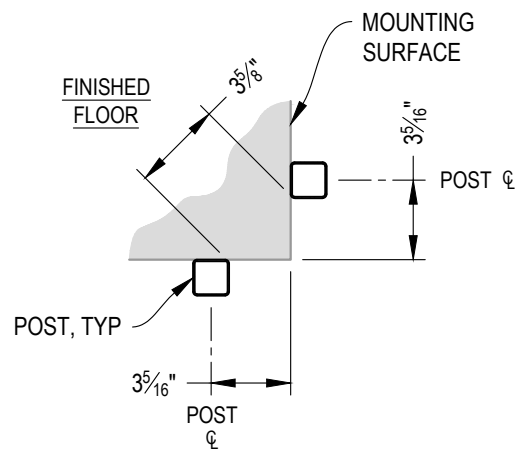

NOTE: 90° SHOWN, OTHER ANGLES SIMILAR

A TYPICAL 90° SIDE MOUNT OUTSIDE CORNER DETAIL

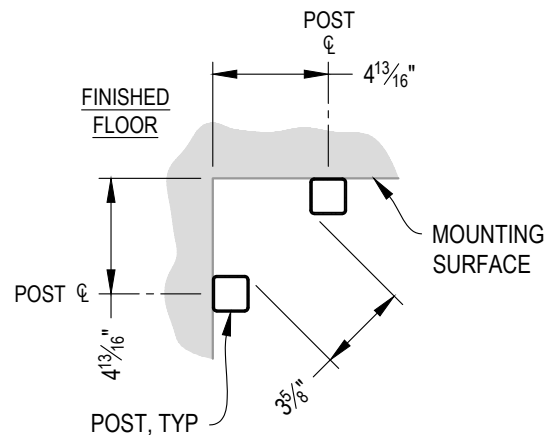

NOTE: 90° SHOWN, OTHER ANGLES SIMILAR

B TYPICAL 90° SIDE MOUNT INSIDE CORNER DETAIL

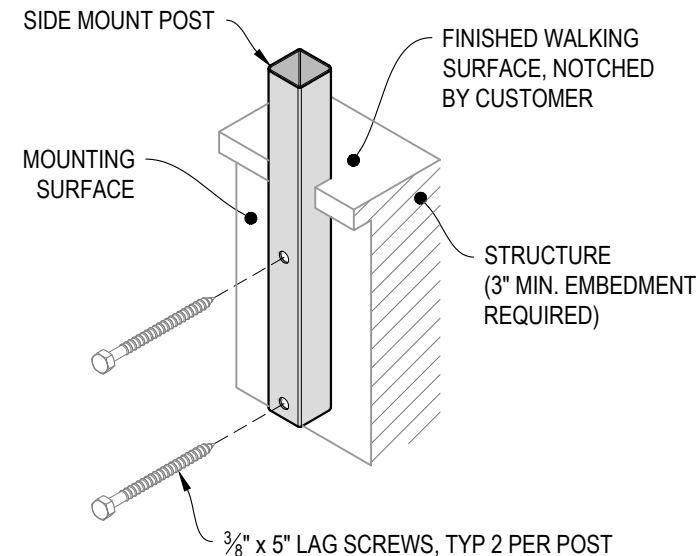

C TYPICAL POST MOUNTING - SIDE MOUNT DETAIL

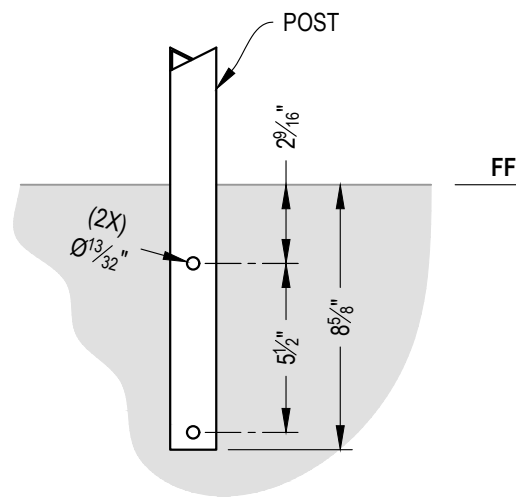

D TYPICAL POST MOUNTING - SIDE MOUNT DETAIL

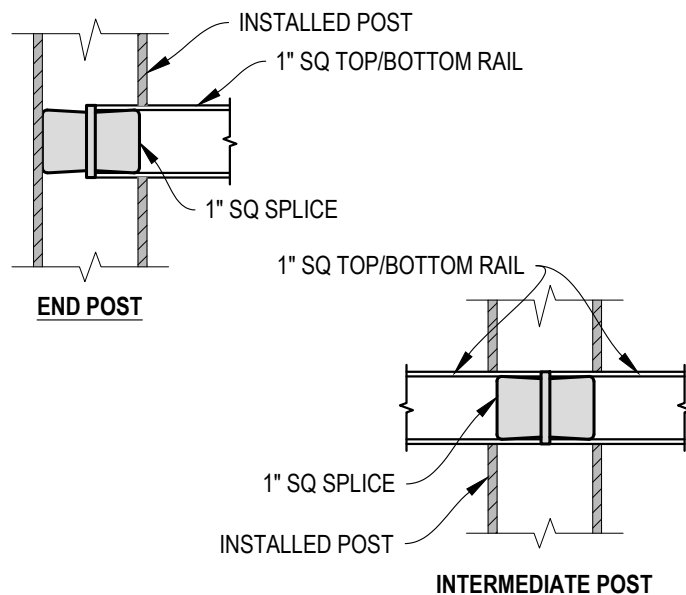

E FITTING INSTALLATION - VERTICAL PANEL RAIL SPLICE DETAIL

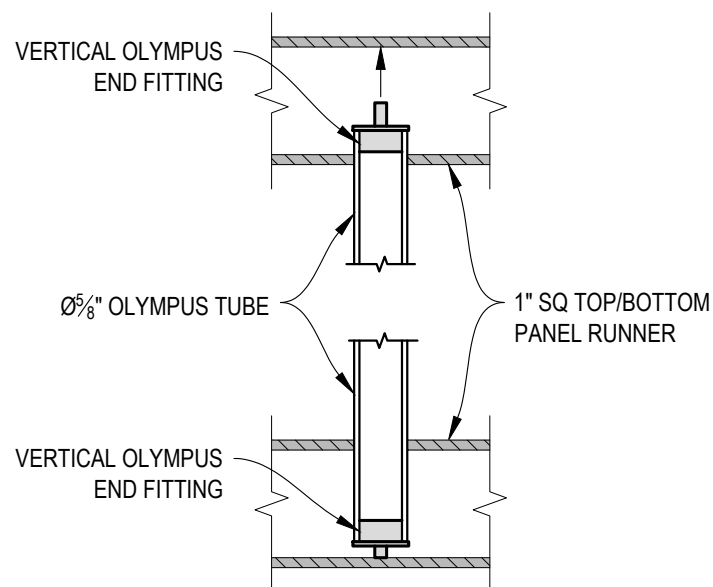

F FITTING INSTALLATION - OLYMPUS INSERT DETAIL

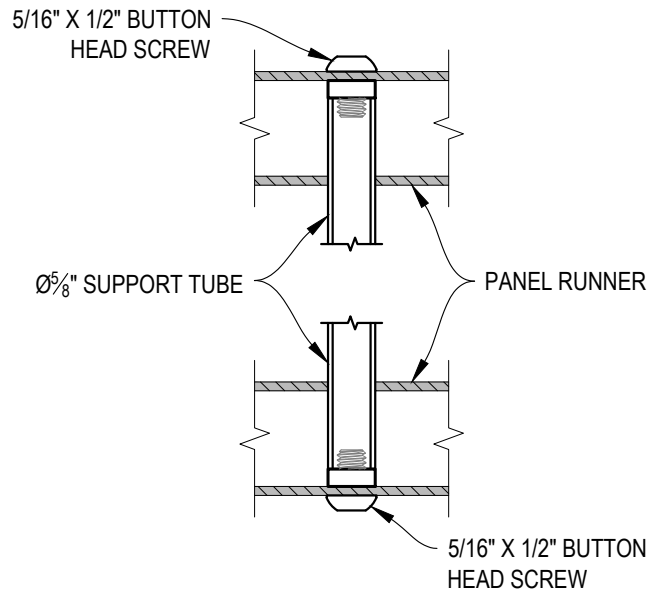

A FITTING INSTALLATION - MIDDLE SUPPORT TUBE
DETAIL

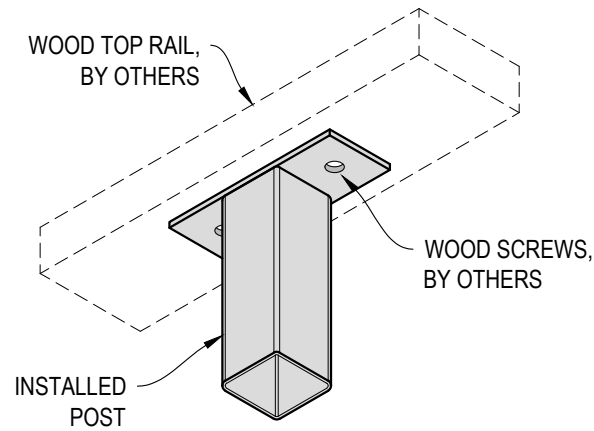

B TOP RAIL INSTALLATION - WOOD
DETAIL

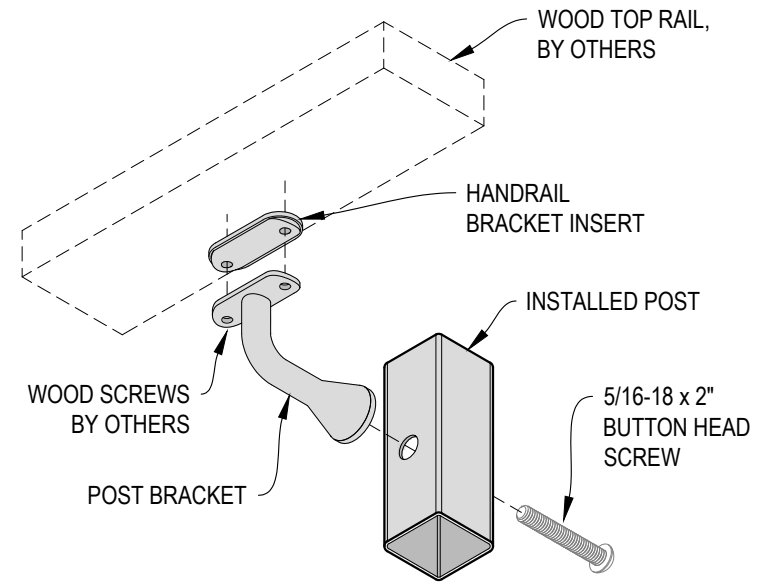

C HANDRAIL POST BRACKET INSTALLATION - WOOD
DETAIL

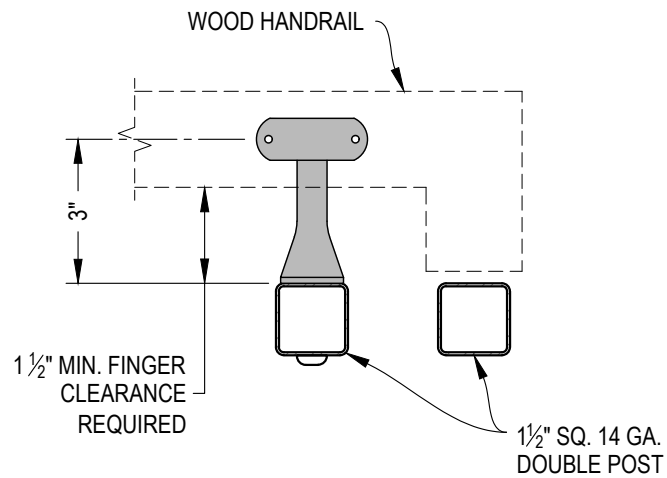

NOTE: VIEW MAY BE MIRRORED

D TYPICAL HANDRAIL RETURN - WOOD
DETAIL