

1 EXAMPLE POST LAYOUT
PLAN VIEW

NOTES:

1. TOP RAIL NOT SHOWN FOR CLARITY.
2. ALL PARTS AND COMPONENTS MADE WITH 316 STAINLESS STEEL UNLESS NOTED OTHERWISE.

LEGEND

- DETAIL ID
- SHEET ID
- ELEVATION ID
- SHEET ID
- SIDE MOUNT POST
- SIDE MOUNT DOUBLE POST
- CENTERLINE
- FINISHED FLOOR
- TYP TYPICAL CONDITION APPLIES ELSEWHERE AT SIMILAR CONDITIONS

NOTES:

1. DECK STRUCTURE CAN VARY GREATLY. IT IS THE RESPONSIBILITY OF THE CUSTOMER TO VERIFY THAT THE SUPPORTING STRUCTURE IS ADEQUATE TO MEET THE LOAD REQUIREMENTS OF THE GOVERNING BUILDING CODE(S). *AGS Stainless Inc.* RECOMMENDS CONSULTING A DESIGN OR CONSTRUCTION PROFESSIONAL TO ADDRESS THESE ISSUES.

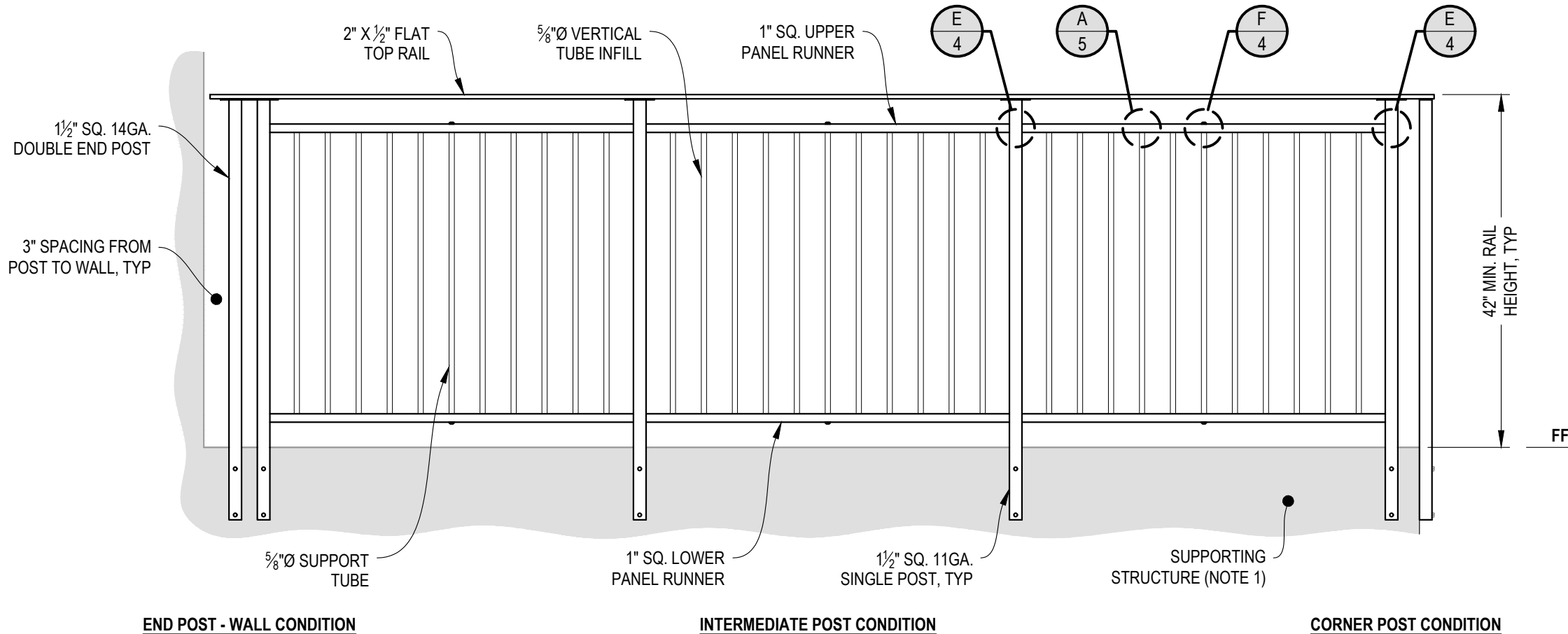

END POST - WALL CONDITION

INTERMEDIATE POST CONDITION

CORNER POST CONDITION

A TYPICAL RAILING CONDITION ELEVATION

VERTICAL OLYMPUS SPECIFICATION DRAWING
** COMMERCIAL **

42" SIDE MOUNT - FLAT TOP

DWG # SM42FC
SCALE NONE
DATE 2026
SHEET

2 OF 5

AGS stainless
CLEARVIEW® Railing Systems

7873 NE DAY ROAD
BAINBRIDGE ISLAND, WA 98110
PHONE - (888) 842-9492
WWW.AGSSTAINLESS.COM

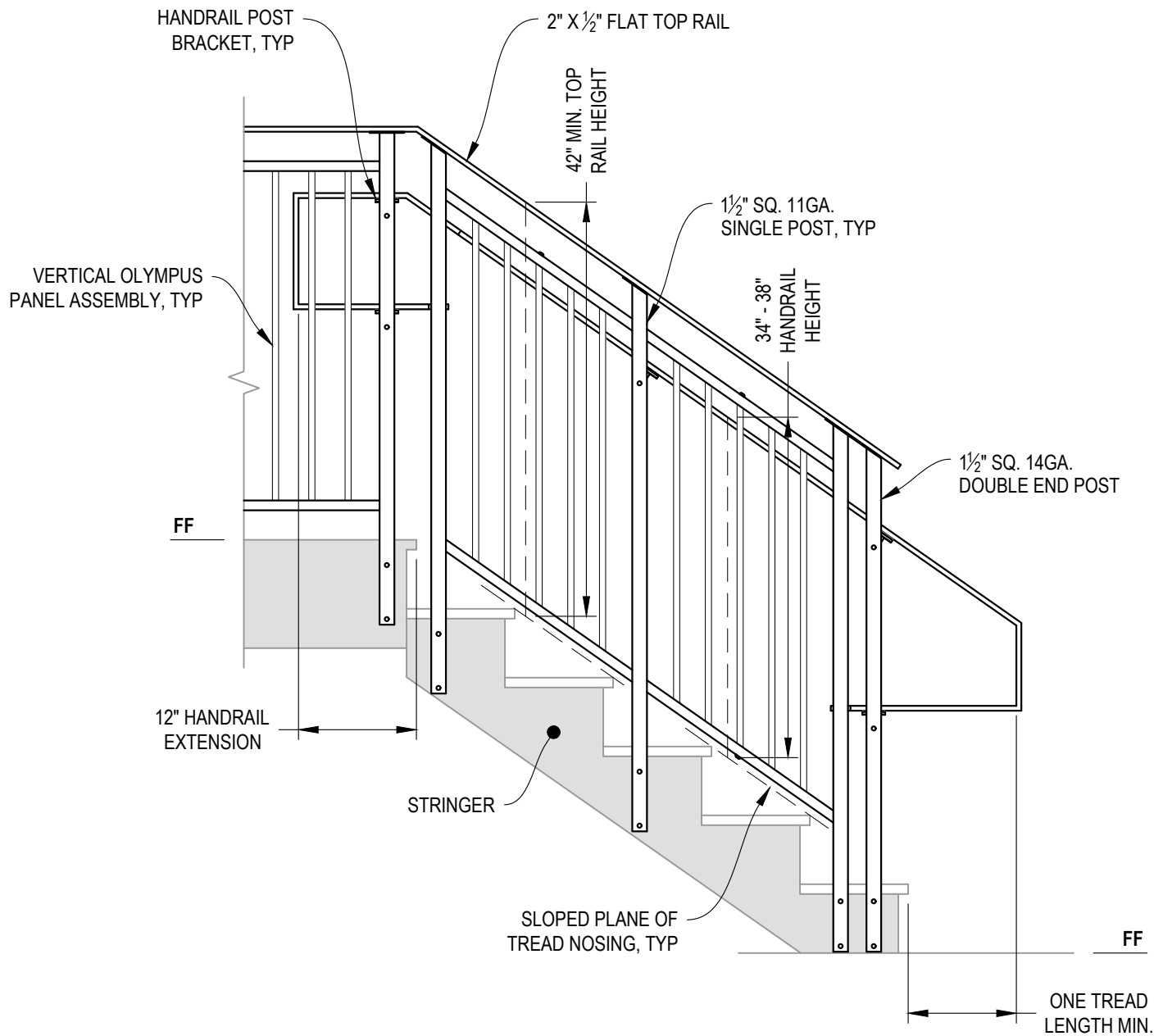

NOTES:

1. STAIR CONSTRUCTION VARIES GREATLY. AS-BUILT CONDITIONS MAY ALTER RAILING DESIGN, INCLUDING POST LOCATION & MOUNTING, INFILL SPACING, AND TOP RAIL LAYOUT.

A STAIR ELEVATION

AGS Stainless Clearview® Railing Systems are designed to meet the requirements of the latest edition of the IRC/IBC.

7873 NEDAY ROAD
BAINBRIDGE ISLAND, WA 98110
PHONE - (888) 842-9492
WWW.AGSSTAINLESS.COM

AGS stainless
CLEARVIEW® Railing Systems

VERTICAL OLYMPUS SPECIFICATION DRAWING
** COMMERCIAL **
42" SIDE MOUNT - FLAT TOP

DWG #	SM42FC
SCALE	NONE
DATE	2026
SHEET	

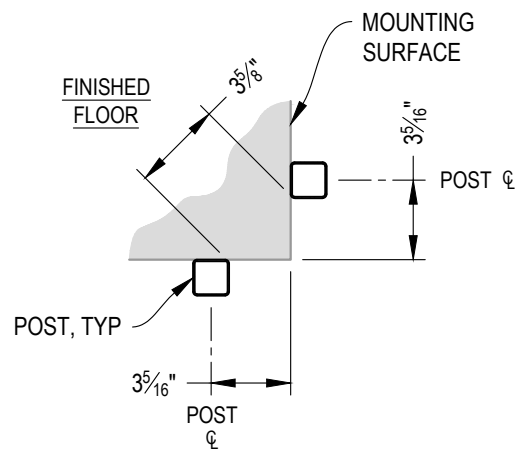

NOTE: 90° SHOWN, OTHER ANGLES SIMILAR

A TYPICAL 90° SIDE MOUNT OUTSIDE CORNER
DETAIL

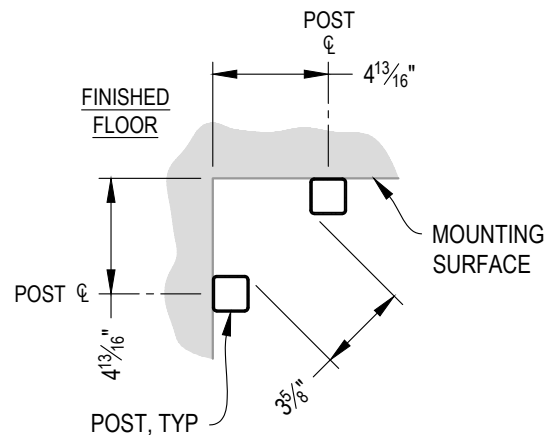

NOTE: 90° SHOWN, OTHER ANGLES SIMILAR

B TYPICAL 90° SIDE MOUNT INSIDE CORNER
DETAIL

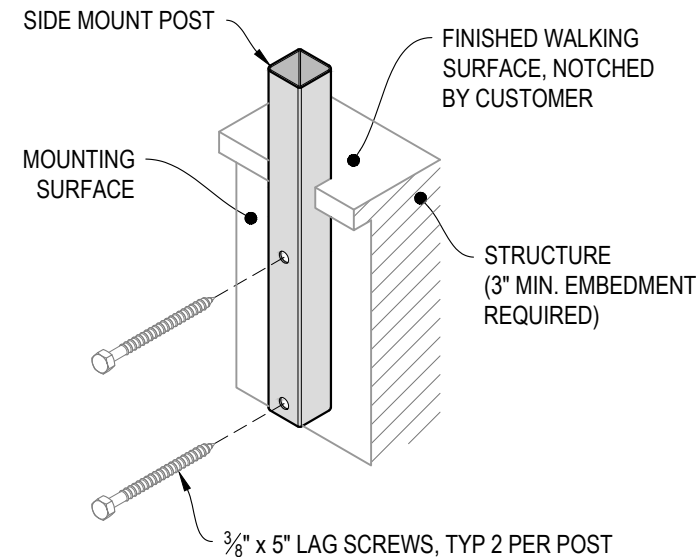

C TYPICAL POST MOUNTING - SIDE MOUNT
DETAIL

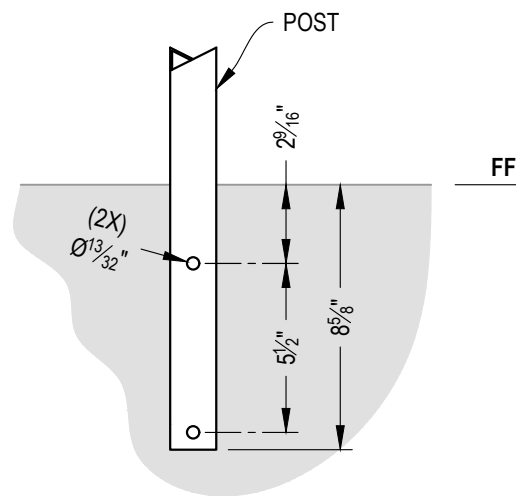

D TYPICAL POST MOUNTING - SIDE MOUNT
DETAIL

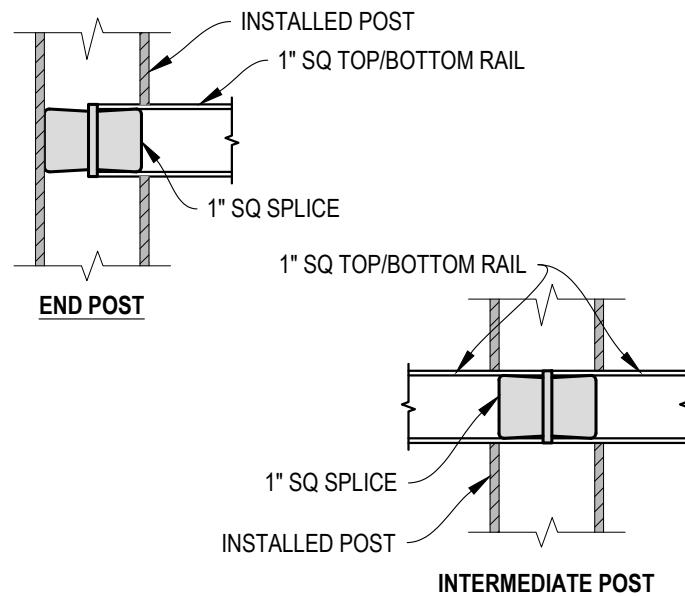

E FITTING INSTALLATION - VERTICAL PANEL RAIL SPLICE
DETAIL

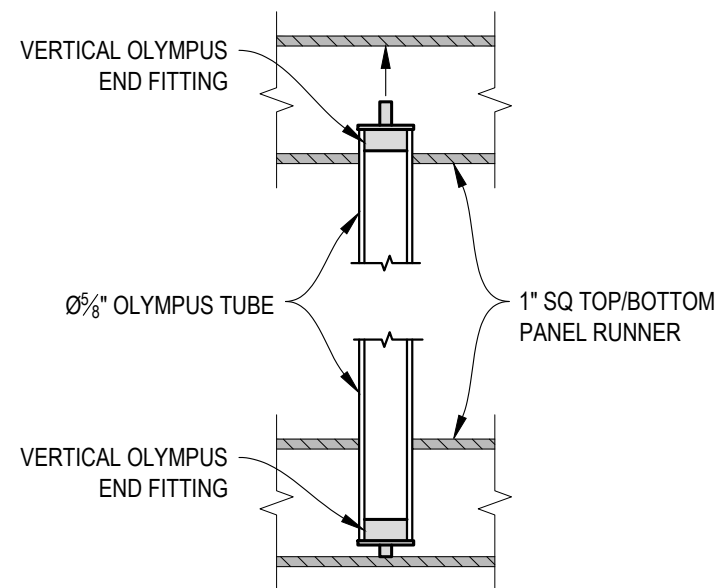

F FITTING INSTALLATION - OLYMPUS INSERT
DETAIL

VERTICAL OLYMPUS SPECIFICATION DRAWING

** COMMERCIAL **

42" SIDE MOUNT - FLAT TOP

DWG # SM42FC

SCALE NONE

DATE 2026

SHEET

4 OF 5

7873 NEDAY ROAD
BAINBRIDGE ISLAND, WA 98110
PHONE - (888) 842-9492
WWW.AGSSTAINLESS.COM

AGS stainless
CLEARVIEW® Railing Systems

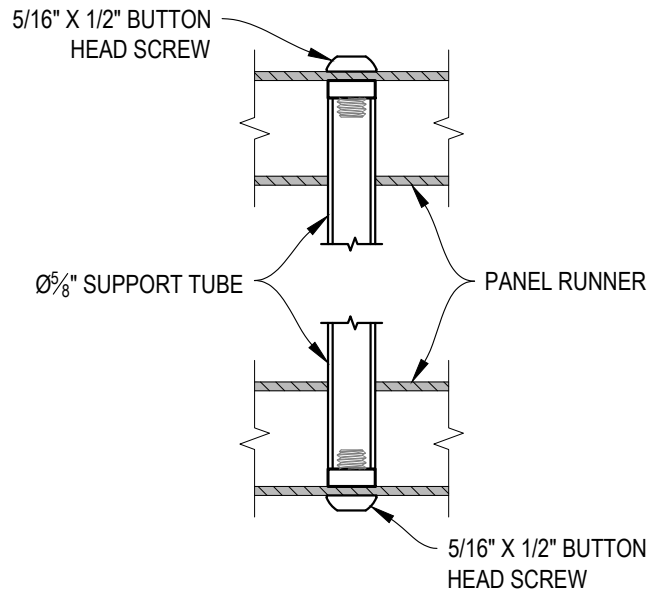

A FITTING INSTALLATION - MIDDLE SUPPORT TUBE
DETAIL

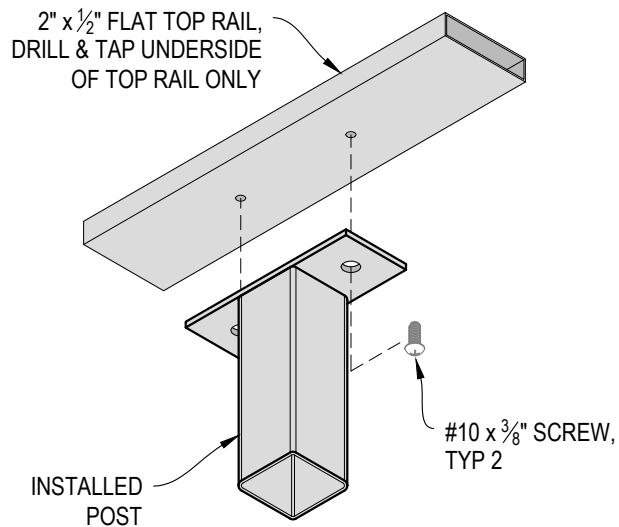

B TOP RAIL INSTALLATION - FLAT
DETAIL

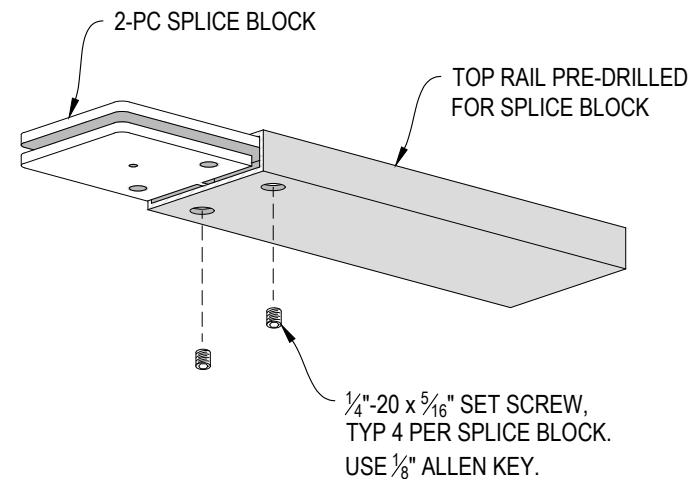

C SPLICE BLOCK ASSEMBLY - FLAT
DETAIL

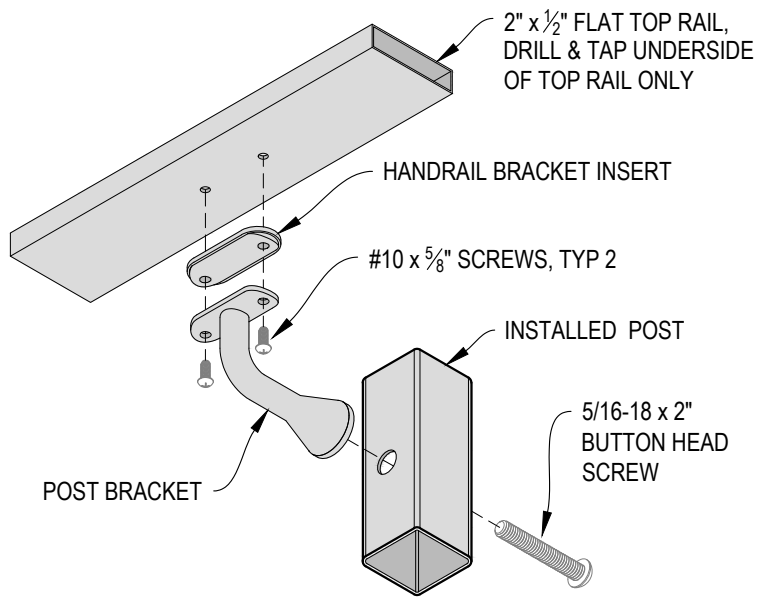

D HANDRAIL POST BRACKET INSTALLATION - FLAT
DETAIL

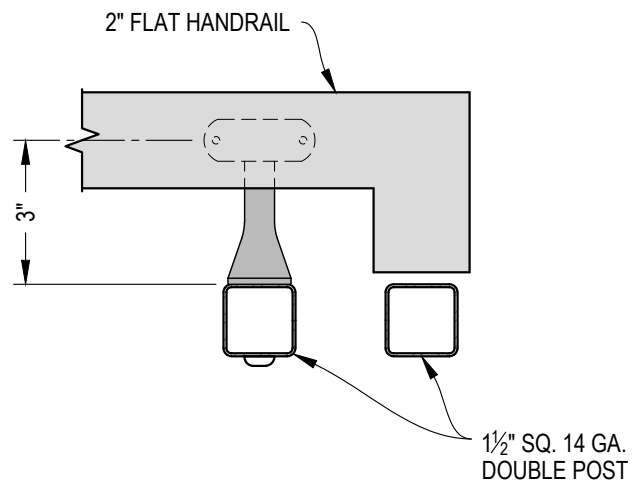

NOTE: VIEW MAY BE MIRRORED

E TYPICAL HANDRAIL RETURN - FLAT
DETAIL