

**1** EXAMPLE POST LAYOUT  
PLAN VIEW

AGS Stainless Clearview® Railing Systems are designed to meet the requirements of the latest edition of the IRC/IBC.

**NOTES:**

1. TOP RAIL NOT SHOWN FOR CLARITY.
2. ALL PARTS AND COMPONENTS MADE WITH 316 STAINLESS STEEL UNLESS NOTED OTHERWISE.

**LEGEND**

- DETAIL ID
- SHEET ID
- ELEVATION ID
- SHEET ID
- SIDE MOUNT POST
- SIDE MOUNT DOUBLE POST
- CENTERLINE
- FINISHED FLOOR
- TYPICAL CONDITION APPLIES ELSEWHERE AT SIMILAR CONDITIONS

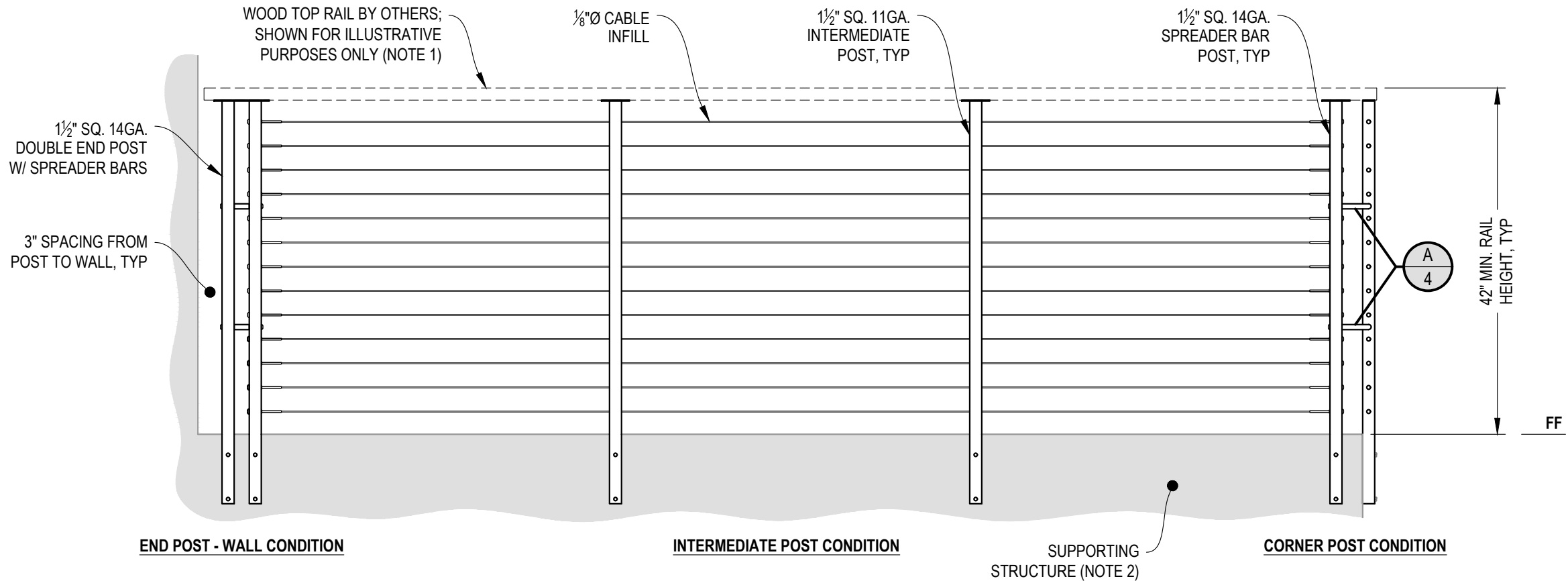

**A** **TYPICAL RAILING CONDITION**  
ELEVATION

**NOTES:**

1. TOP RAIL SHOULD BE SELECTED SO THAT ALL GOVERNING CODE REQUIREMENTS ARE SATISFIED. THESE INCLUDE SHAPE, STRENGTH AND RAILING HEIGHT.
2. DECK STRUCTURE CAN VARY GREATLY. IT IS THE RESPONSIBILITY OF THE CUSTOMER TO VERIFY THAT THE SUPPORTING STRUCTURE IS ADEQUATE TO MEET THE LOAD REQUIREMENTS OF THE GOVERNING BUILDING CODE(S). AGS Stainless Inc. RECOMMENDS CONSULTING A DESIGN OR CONSTRUCTION PROFESSIONAL TO ADDRESS THESE ISSUES.

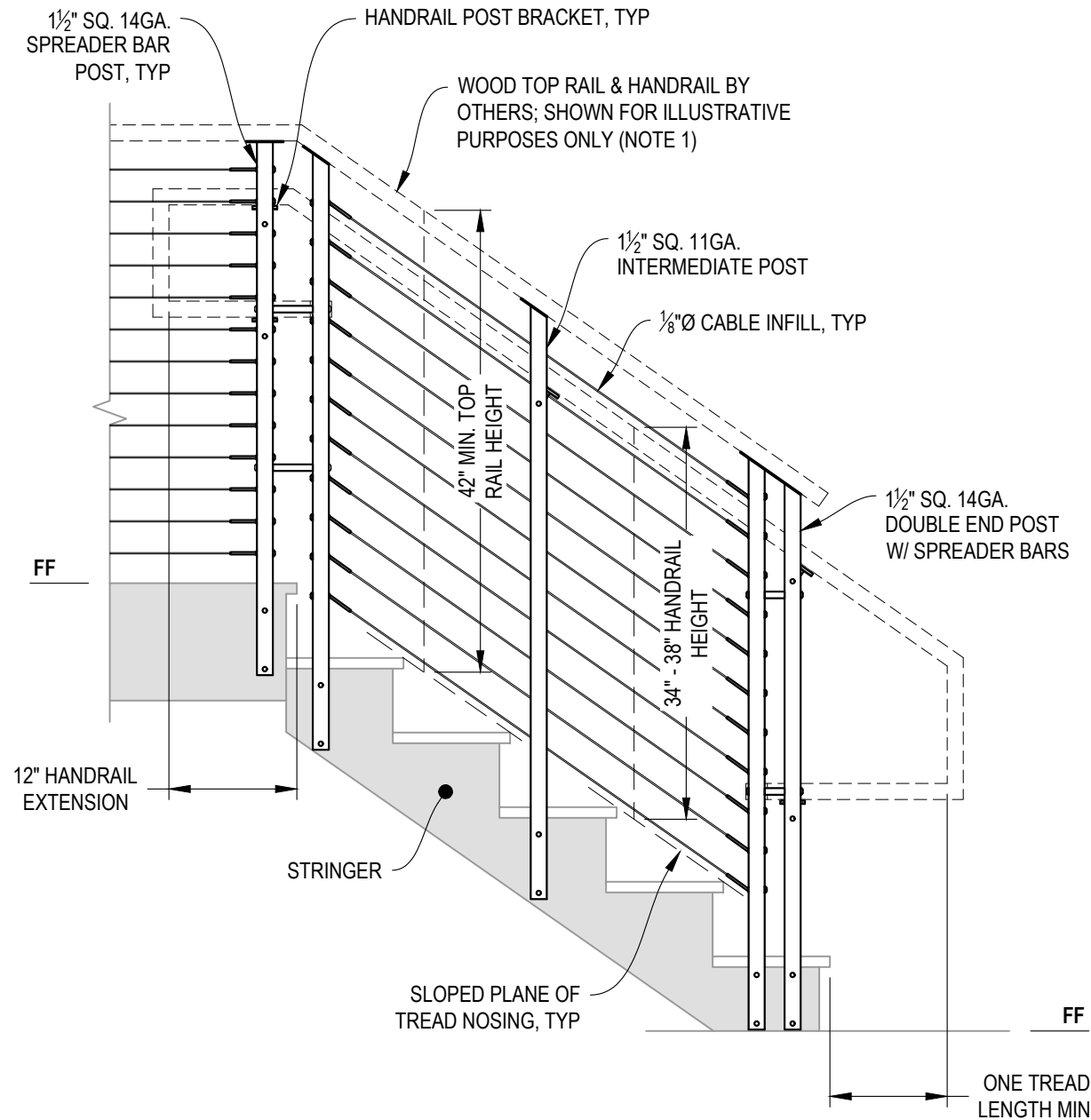

**A** STAIR ELEVATION

**NOTES:**

1. TOP RAIL SHOULD BE SELECTED SO THAT ALL GOVERNING CODE REQUIREMENTS ARE SATISFIED. THESE INCLUDE SHAPE, STRENGTH, AND RAILING HEIGHT.
2. STAIR CONSTRUCTION VARIES GREATLY. AS-BUILT CONDITIONS MAY ALTER RAILING DESIGN, INCLUDING POST LOCATION & MOUNTING, INFILL SPACING, AND TOP RAIL LAYOUT.

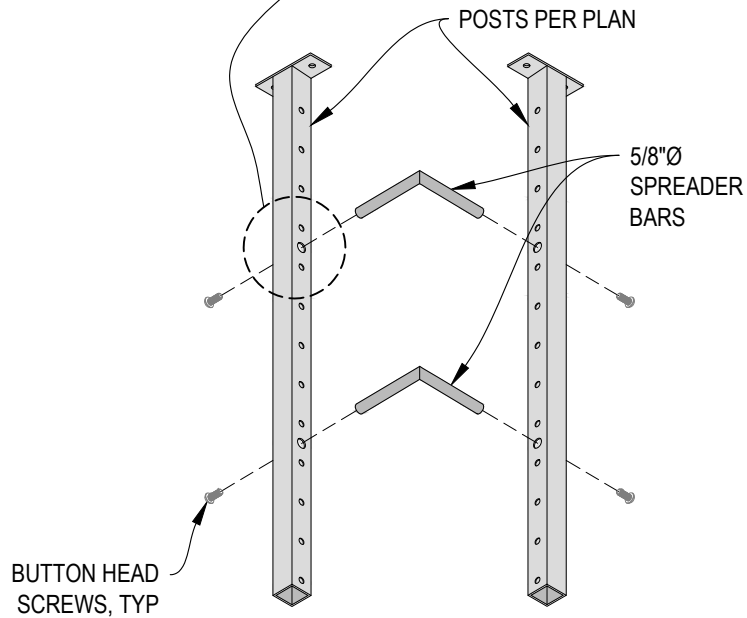
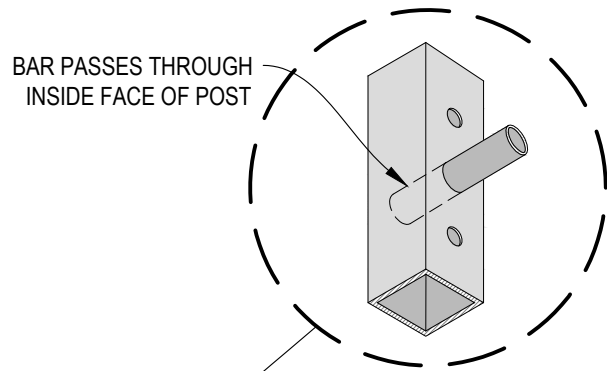

**A** CORNER POST ASSEMBLY  
DETAIL

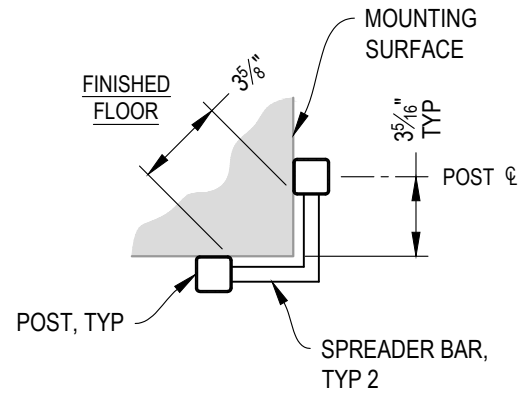

NOTE: 90° SHOWN, OTHER ANGLES SIMILAR

**B** TYPICAL 90° SIDE MOUNT OUTSIDE CORNER  
DETAIL

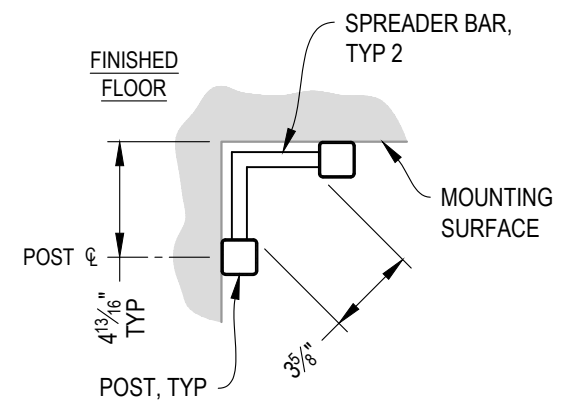

NOTE: 90° SHOWN, OTHER ANGLES SIMILAR

**C** TYPICAL 90° SIDE MOUNT INSIDE CORNER  
DETAIL

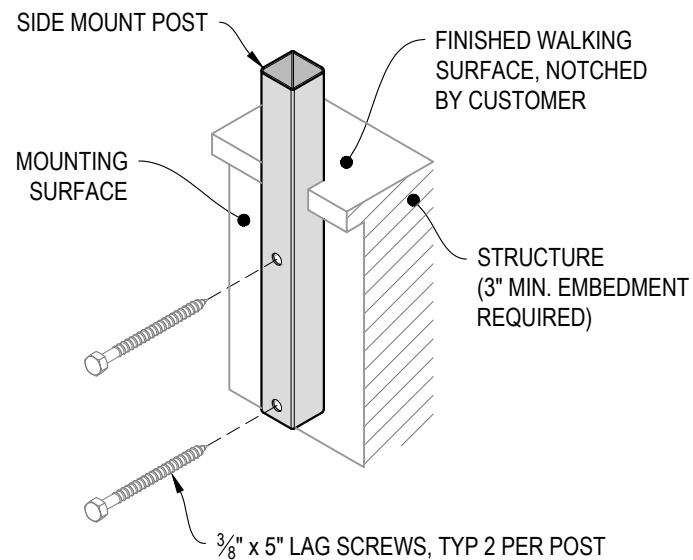

**D** TYPICAL POST MOUNTING - SIDE MOUNT  
DETAIL

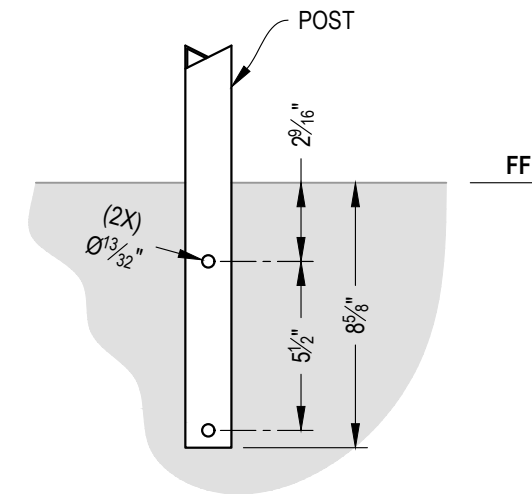

**E** TYPICAL POST MOUNTING - SIDE MOUNT  
DETAIL

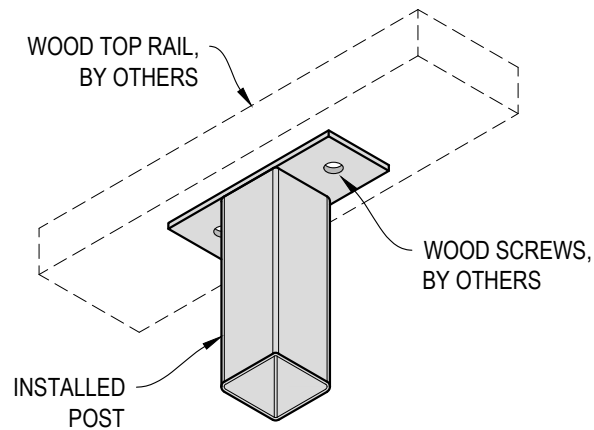

**A** TOP RAIL INSTALLATION - WOOD  
DETAIL

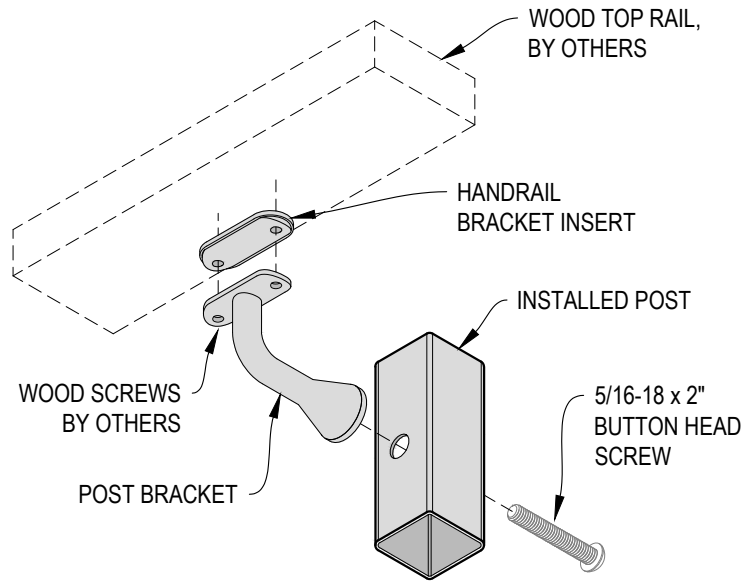

**B** HANDRAIL POST BRACKET INSTALLATION - WOOD  
DETAIL

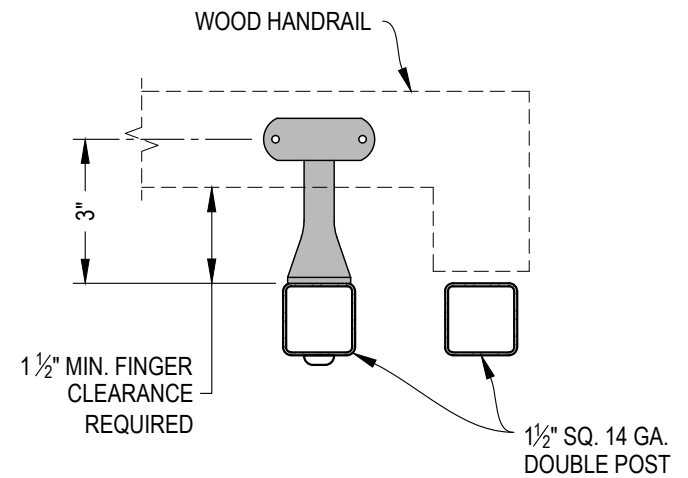

**C** TYPICAL HANDRAIL RETURN - WOOD  
DETAIL

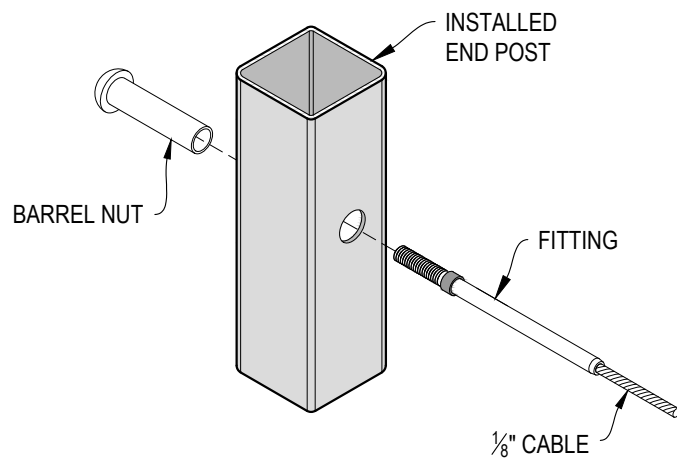

**D** FITTING INSTALLATION - BARREL NUT  
DETAIL

AGS Stainless Clearview® Railing Systems are designed to meet the requirements of the latest edition of the IRC/IBC.

7873 NEDAY ROAD  
BAINBRIDGE ISLAND, WA 98110  
PHONE - (888) 842-9492  
WWW.AGSSTAINLESS.COM

**AGS** stainless  
CLEARVIEW® Railing Systems

RAINIER SPECIFICATION DRAWING  
\*\* COMMERCIAL \*\*

42" SIDE MOUNT - WOOD TOP

DWG #  
SM42WC

SCALE  
NONE

DATE  
2026

SHEET

**5**  
OF 5