

1 EXAMPLE POST LAYOUT
PLAN VIEW

AGS Stainless Clearview® Railing Systems are designed to meet the requirements of the latest edition of the IRC/IBC.

NOTES:

1. TOP RAIL NOT SHOWN FOR CLARITY.
2. ALL PARTS AND COMPONENTS MADE WITH 316 STAINLESS STEEL UNLESS NOTED OTHERWISE.

LEGEND

- DETAIL ID
- SHEET ID
- ELEVATION ID
- SHEET ID
- CORE DRILL POST
- CORE DRILL DOUBLE POST
- CENTERLINE
- FF** FINISHED FLOOR
- TYP TYPICAL CONDITION APPLIES ELSEWHERE AT SIMILAR CONDITIONS

7873 NE DAY ROAD
BAINBRIDGE ISLAND, WA 98110
PHONE - (888) 842-9492
WWW.AGSSTAINLESS.COM

AGS stainless
CLEARVIEW® Railing Systems

RAINIER SPECIFICATION DRAWING
** COMMERCIAL **

42" CORE DRILL - FLAT TOP

DWG #	CD42FC
SCALE	NONE
DATE	2026
SHEET	1 OF 5

NOTES:

1. DECK STRUCTURE CAN VARY GREATLY. IT IS THE RESPONSIBILITY OF THE CUSTOMER TO VERIFY THAT THE SUPPORTING STRUCTURE IS ADEQUATE TO MEET THE LOAD REQUIREMENTS OF THE GOVERNING BUILDING CODE(S). AGS Stainless Inc. RECOMMENDS CONSULTING A DESIGN OR CONSTRUCTION PROFESSIONAL TO ADDRESS THESE ISSUES.

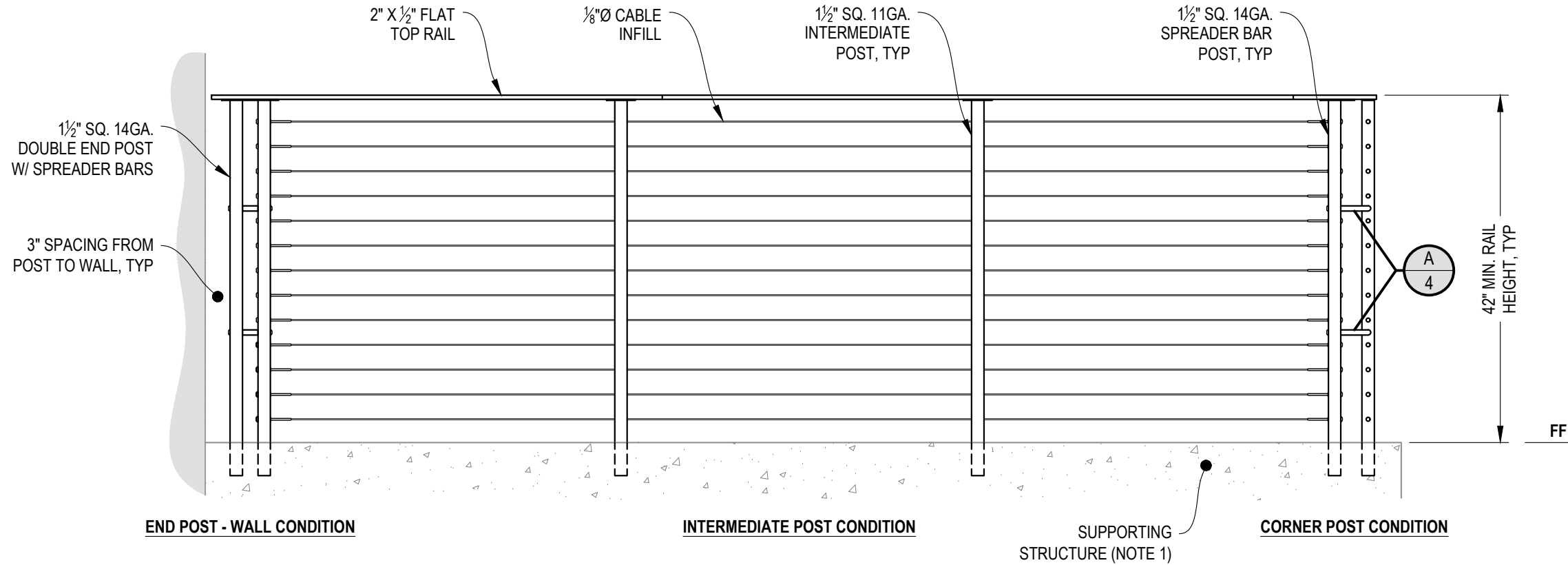

A TYPICAL RAILING CONDITION ELEVATION

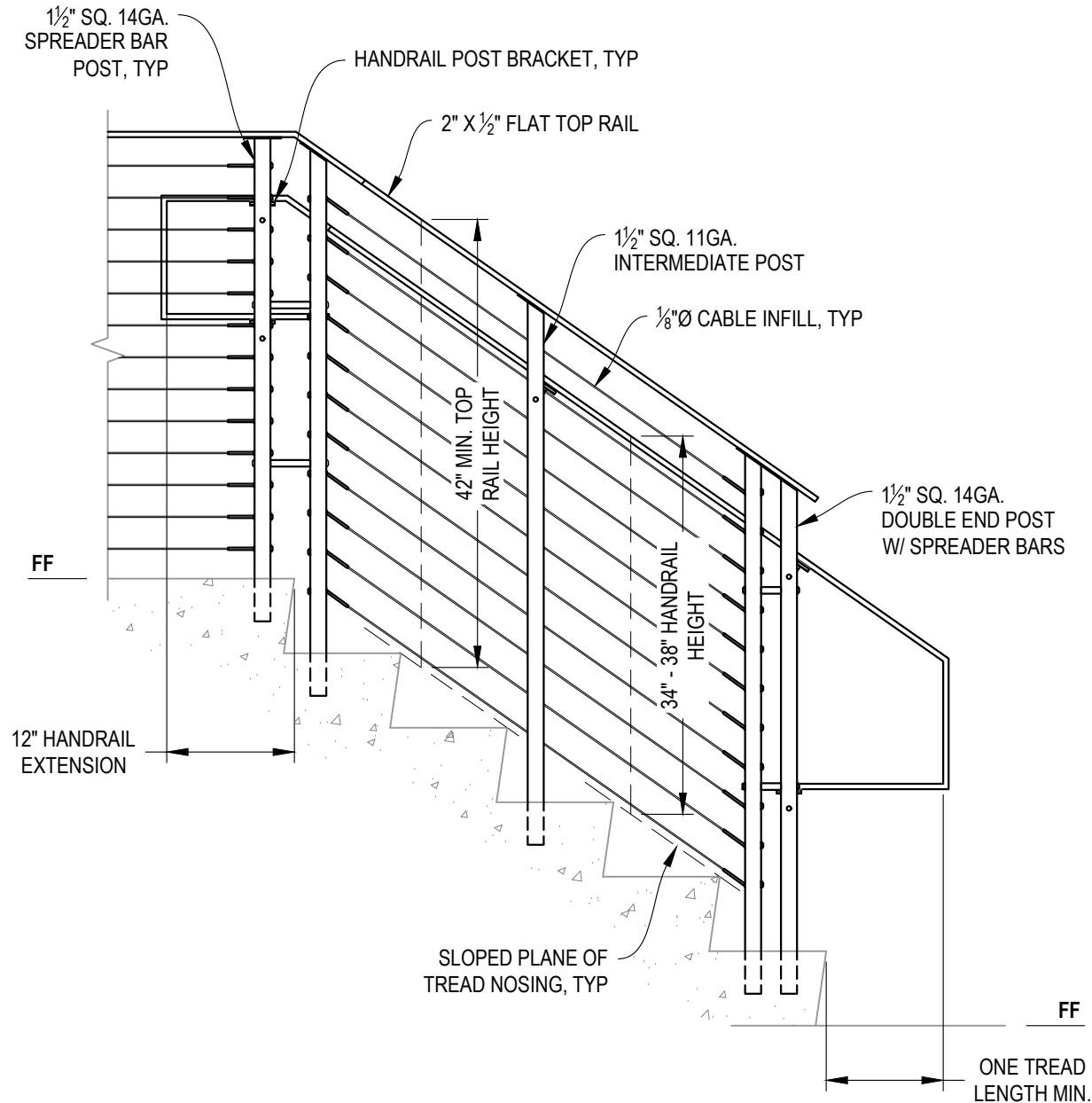

A STAIR ELEVATION

NOTES:

1. STAIR CONSTRUCTION VARIES GREATLY. AS-BUILT CONDITIONS MAY ALTER RAILING DESIGN, INCLUDING POST LOCATION & MOUNTING, INFILL SPACING, AND TOP RAIL LAYOUT.

7873 NEDAY ROAD
 BAINBRIDGE ISLAND, WA 98110
 PHONE - (888) 842-9492
 WWW.AGSSSTAINLESS.COM



RAINIER SPECIFICATION DRAWING
 ** COMMERCIAL **

42" CORE DRILL - FLAT TOP

DWG #	CD42FC
SCALE	NONE
DATE	2026
SHEET	

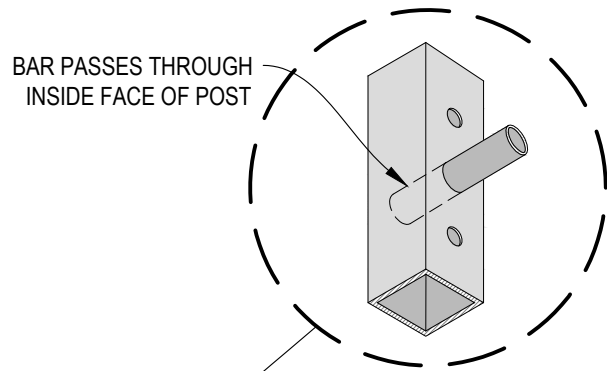

BAR PASSES THROUGH INSIDE FACE OF POST

POSTS PER PLAN

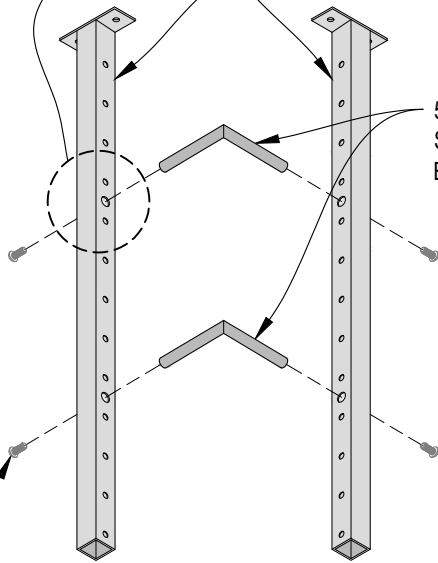

5/8"Ø SPREADER BARS

BUTTON HEAD SCREWS, TYP

A CORNER POST ASSEMBLY
DETAIL

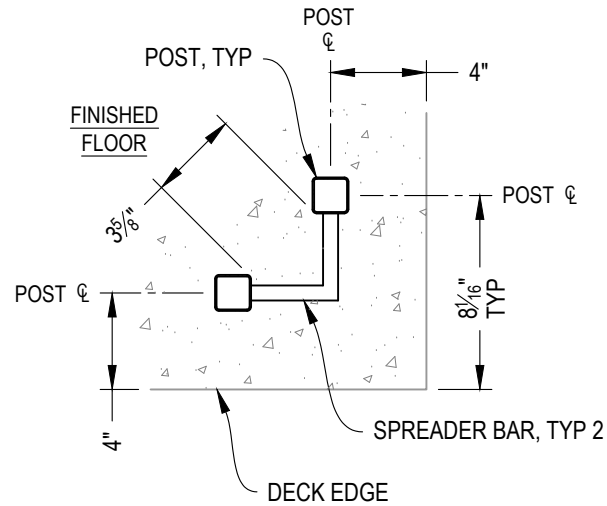

NOTE: 90° SHOWN, OTHER ANGLES SIMILAR

B TYPICAL 90° TOP MOUNT OUTSIDE CORNER
DETAIL

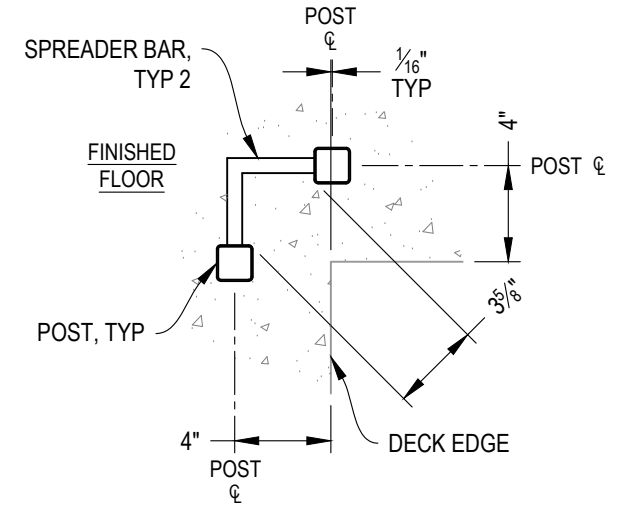

NOTE: 90° SHOWN, OTHER ANGLES SIMILAR

C TYPICAL 90° TOP MOUNT INSIDE CORNER
DETAIL

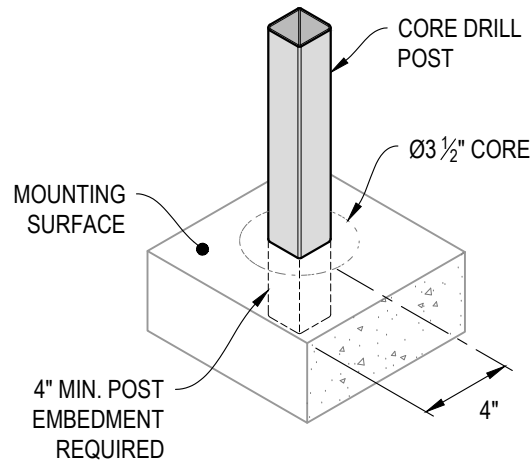

D TYPICAL POST MOUNTING - CORE DRILL
DETAIL

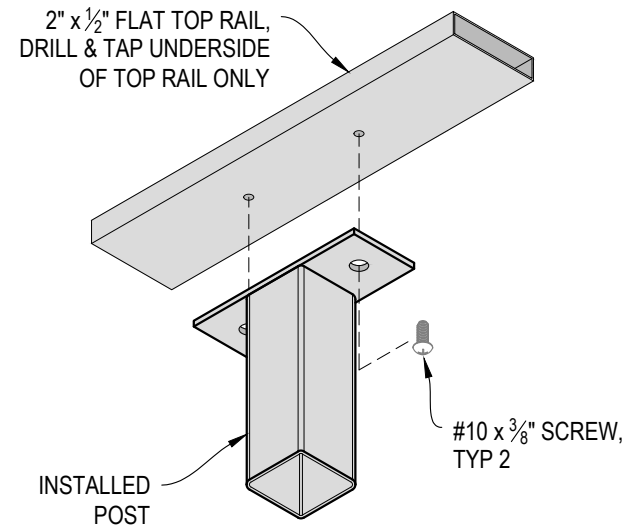

E TOP RAIL INSTALLATION - FLAT
DETAIL

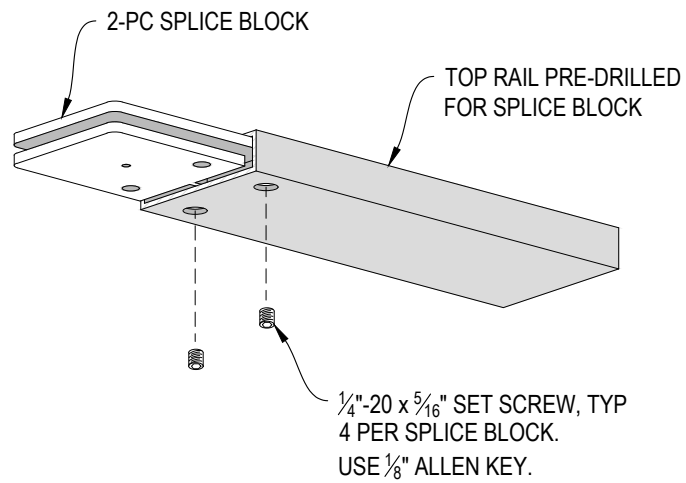

A SPLICE BLOCK ASSEMBLY - FLAT
DETAIL

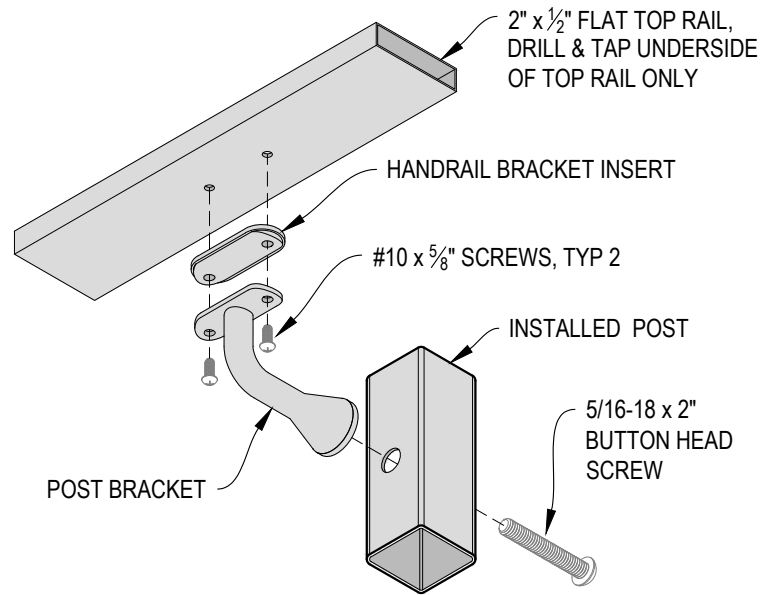

B HANDRAIL POST BRACKET INSTALLATION - FLAT
DETAIL

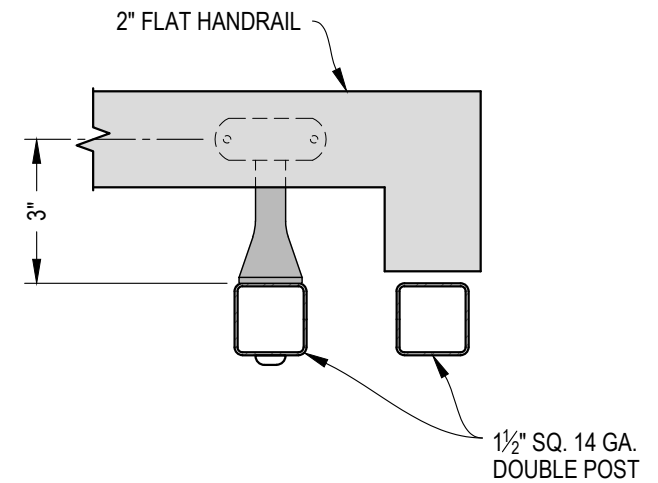

C TYPICAL HANDRAIL RETURN - FLAT
DETAIL

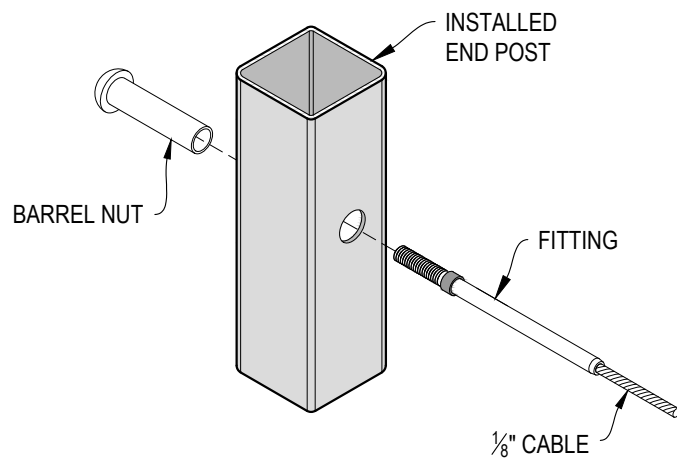

D FITTING INSTALLATION - BARREL NUT
DETAIL

AGS Stainless Clearview® Railing Systems are designed to meet the requirements of the latest edition of the IRC/IBC.

7873 NEDAY ROAD
BAINBRIDGE ISLAND, WA 98110
PHONE - (888) 842-9492
WWW.AGSSTAINLESS.COM

AGS stainless
CLEARVIEW® Railing Systems

RAINIER SPECIFICATION DRAWING
** COMMERCIAL **

42" CORE DRILL - FLAT TOP

DWG #
CD42FC

SCALE
NONE

DATE
2026

SHEET

5
OF 5