

1 **EXAMPLE POST LAYOUT**
PLAN VIEW

AGS Stainless Clearview® Railing Systems are designed to meet the requirements of the latest edition of the IRC/IBC.

NOTES:

1. TOP RAIL NOT SHOWN FOR CLARITY.
2. ALL PARTS AND COMPONENTS MADE WITH 316 STAINLESS STEEL UNLESS NOTED OTHERWISE.

LEGEND

- DETAIL ID
- SHEET ID
- ELEVATION ID
- TOP MOUNT POST
- TOP MOUNT DOUBLE POST
- CENTERLINE
- FINISHED FLOOR
- TYPICAL CONDITION APPLIES ELSEWHERE AT SIMILAR CONDITIONS

7873 NE DAY ROAD
BAINBRIDGE ISLAND, WA 98110
PHONE - (888) 842-9492
WWW.AGSSTAINLESS.COM

AGS stainless
CLEARVIEW® Railing Systems

OLYMPUS SPECIFICATION DRAWING
** COMMERCIAL **

42" TOP MOUNT - FLAT TOP

DWG #	TM42FC
SCALE	NONE
DATE	2026
SHEET	1 OF 5

NOTES:

1. DECK STRUCTURE CAN VARY GREATLY. IT IS THE RESPONSIBILITY OF THE CUSTOMER TO VERIFY THAT THE SUPPORTING STRUCTURE IS ADEQUATE TO MEET THE LOAD REQUIREMENTS OF THE GOVERNING BUILDING CODE(S). *AGS Stainless Inc.* RECOMMENDS CONSULTING A DESIGN OR CONSTRUCTION PROFESSIONAL TO ADDRESS THESE ISSUES.

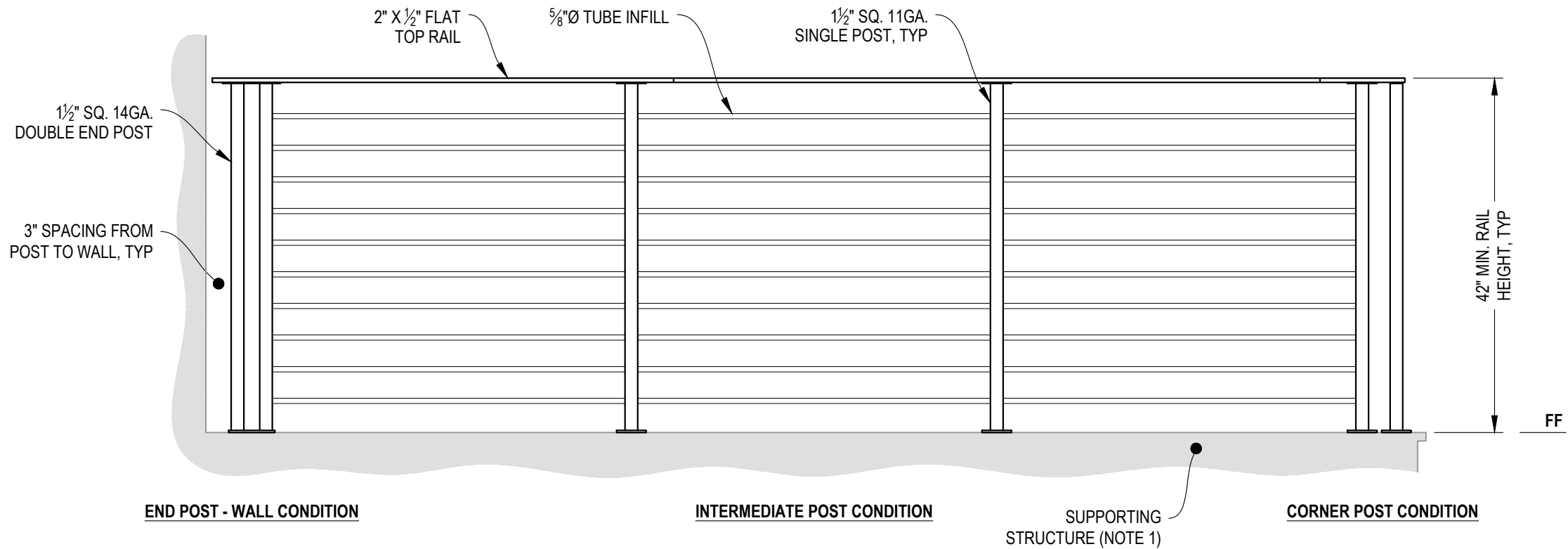

A **TYPICAL RAILING CONDITION**
ELEVATION

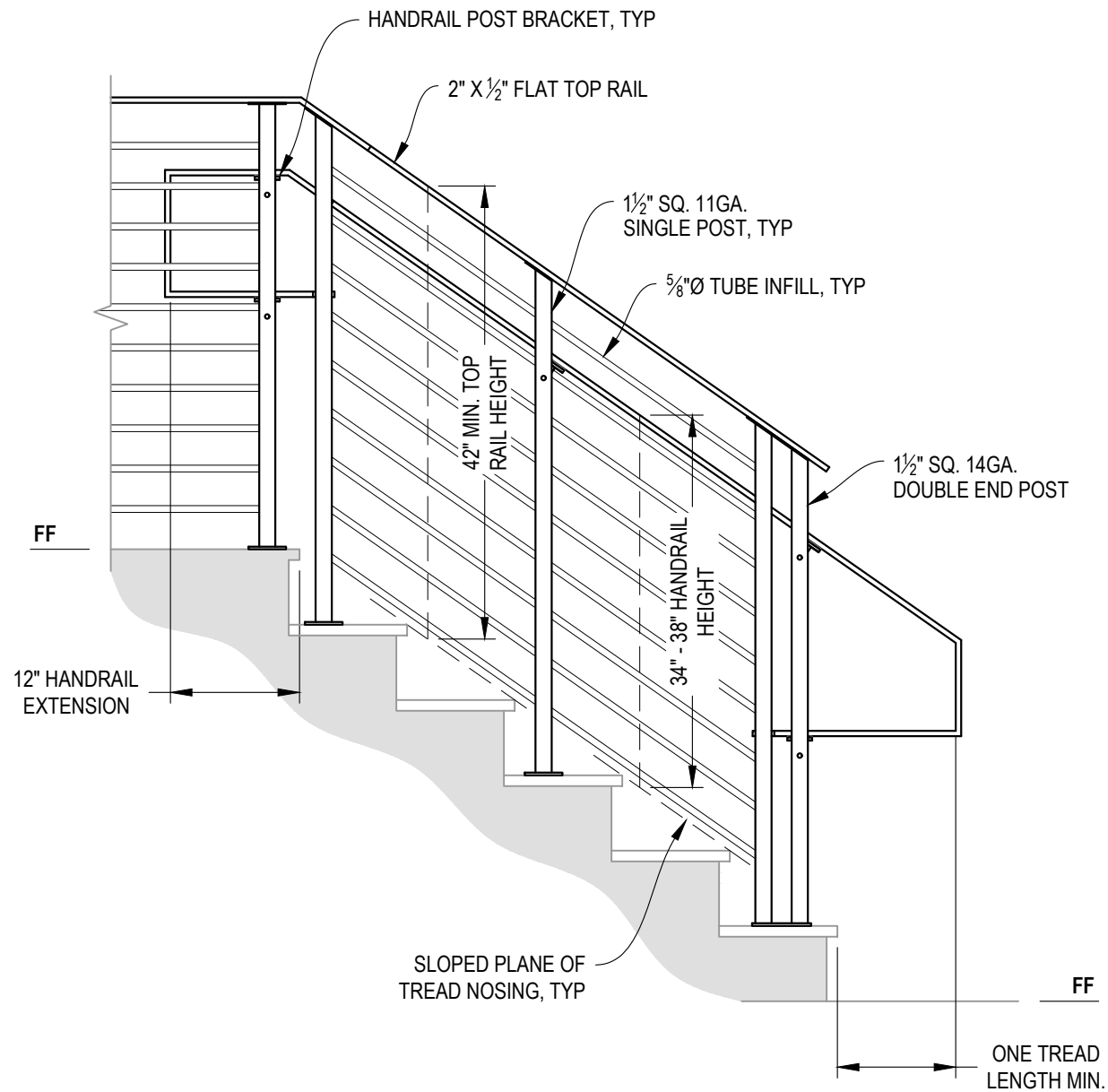

A STAIR
ELEVATION

NOTES:

1. STAIR CONSTRUCTION VARIES GREATLY. AS-BUILT CONDITIONS MAY ALTER RAILING DESIGN, INCLUDING POST LOCATION & MOUNTING, INFILL SPACING, AND TOP RAIL LAYOUT.

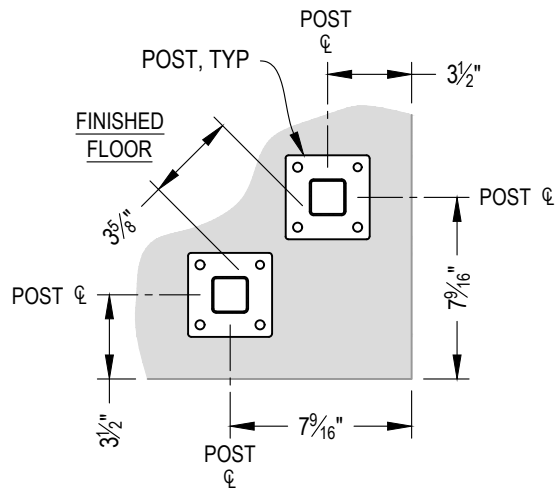

NOTE: 90° SHOWN, OTHER ANGLES SIMILAR

A TYPICAL 90° TOP MOUNT OUTSIDE CORNER
DETAIL

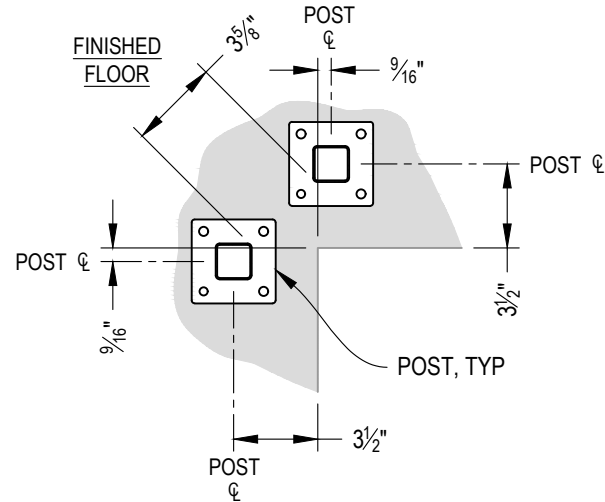

NOTE: 90° SHOWN, OTHER ANGLES SIMILAR

B TYPICAL 90° TOP MOUNT INSIDE CORNER
DETAIL

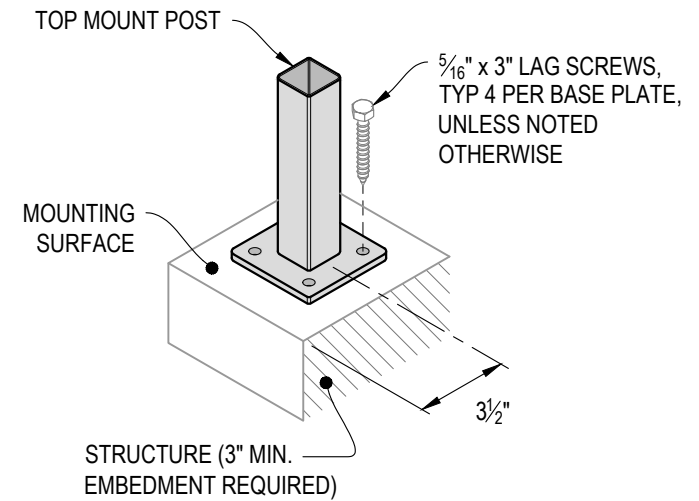

C TYPICAL POST MOUNTING - TOP MOUNT
DETAIL

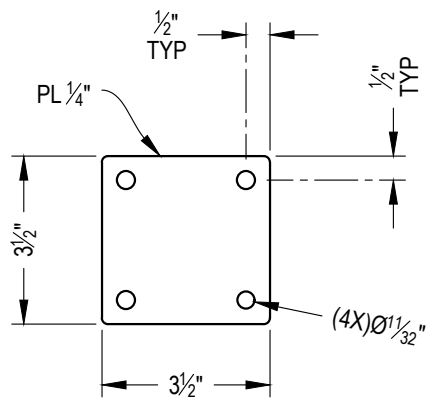

D TYPICAL BASE PLATE
DETAIL

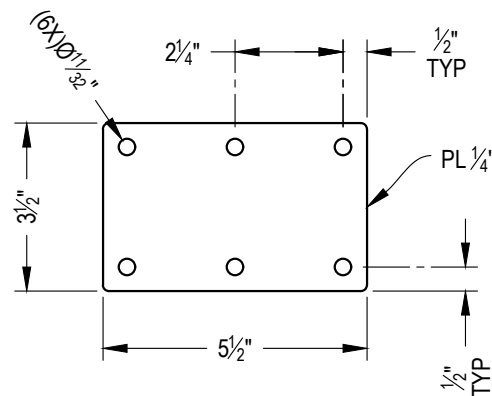

E TYPICAL DOUBLE BASE PLATE
DETAIL

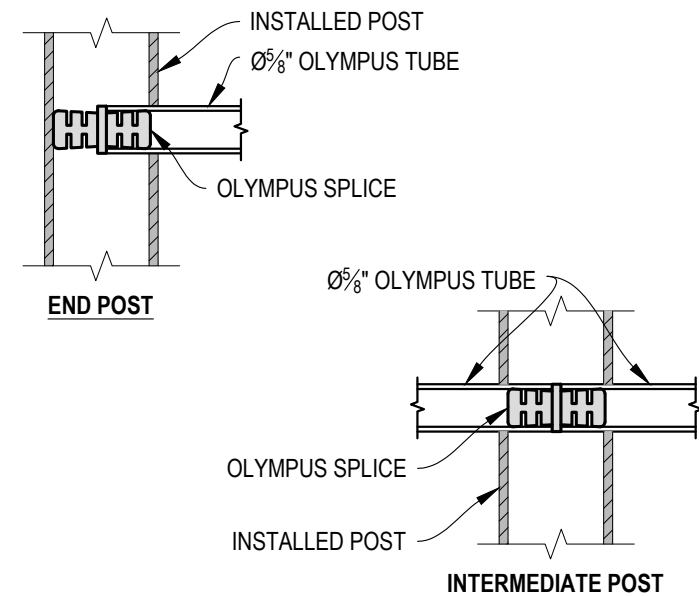

F FITTING INSTALLATION - OLYMPUS SPLICE
DETAIL

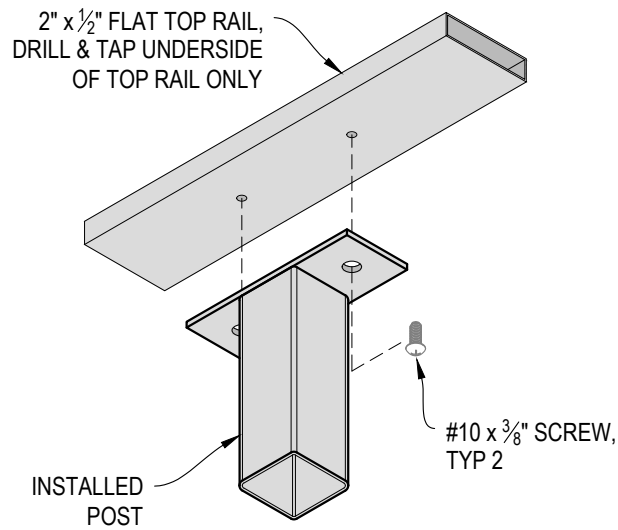

A TOP RAIL INSTALLATION - FLAT
DETAIL

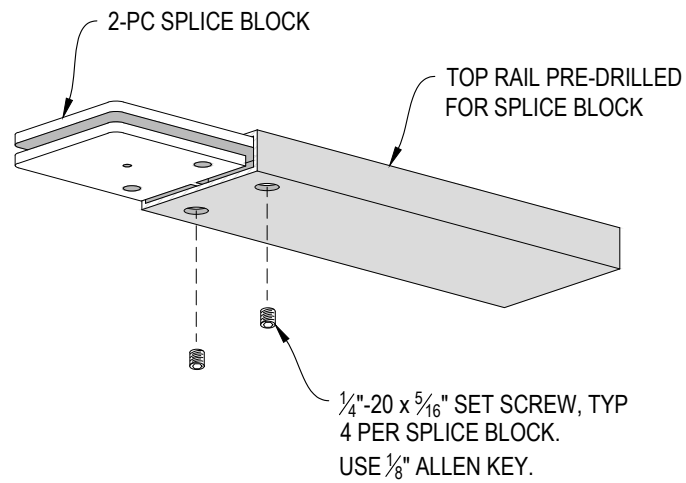

B SPLICE BLOCK ASSEMBLY - FLAT
DETAIL

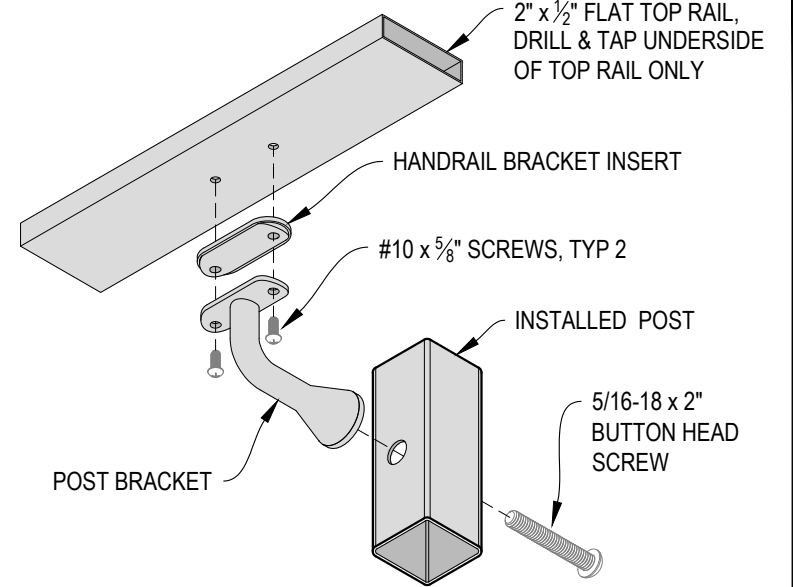

C HANDRAIL POST BRACKET INSTALLATION - FLAT
DETAIL

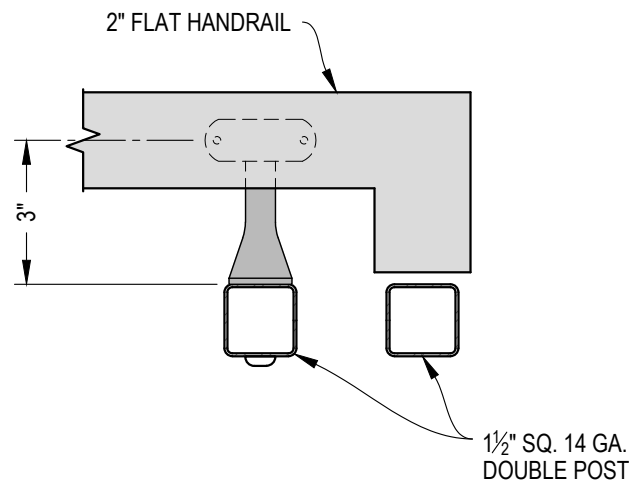

NOTE: VIEW MAY BE MIRRORED

D TYPICAL HANDRAIL RETURN - FLAT
DETAIL