

**1** EXAMPLE POST LAYOUT  
PLAN VIEW

AGS Stainless Clearview® Railing Systems are designed to meet the requirements of the latest edition of the IRC/IBC.

**NOTES:**

1. TOP RAIL NOT SHOWN FOR CLARITY.
2. ALL PARTS AND COMPONENTS MADE WITH 316 STAINLESS STEEL UNLESS NOTED OTHERWISE.

**LEGEND**

- DETAIL ID
- SHEET ID
- ELEVATION ID
- SHEET ID
- SIDE MOUNT POST
- SIDE MOUNT DOUBLE POST
- CENTERLINE
- FINISHED FLOOR
- TYPICAL CONDITION APPLIES ELSEWHERE AT SIMILAR CONDITIONS

7873 NE DAY ROAD  
BAINBRIDGE ISLAND, WA 98110  
PHONE - (888) 842-9492  
WWW.AGSSTAINLESS.COM

**AGS stainless**  
CLEARVIEW® Railing Systems

OLYMPUS SPECIFICATION DRAWING  
\*\* COMMERCIAL \*\*

**42" SIDE MOUNT - WOOD TOP**

DWG #	SM42WC
SCALE	NONE
DATE	2026
SHEET	<b>1</b> OF 5

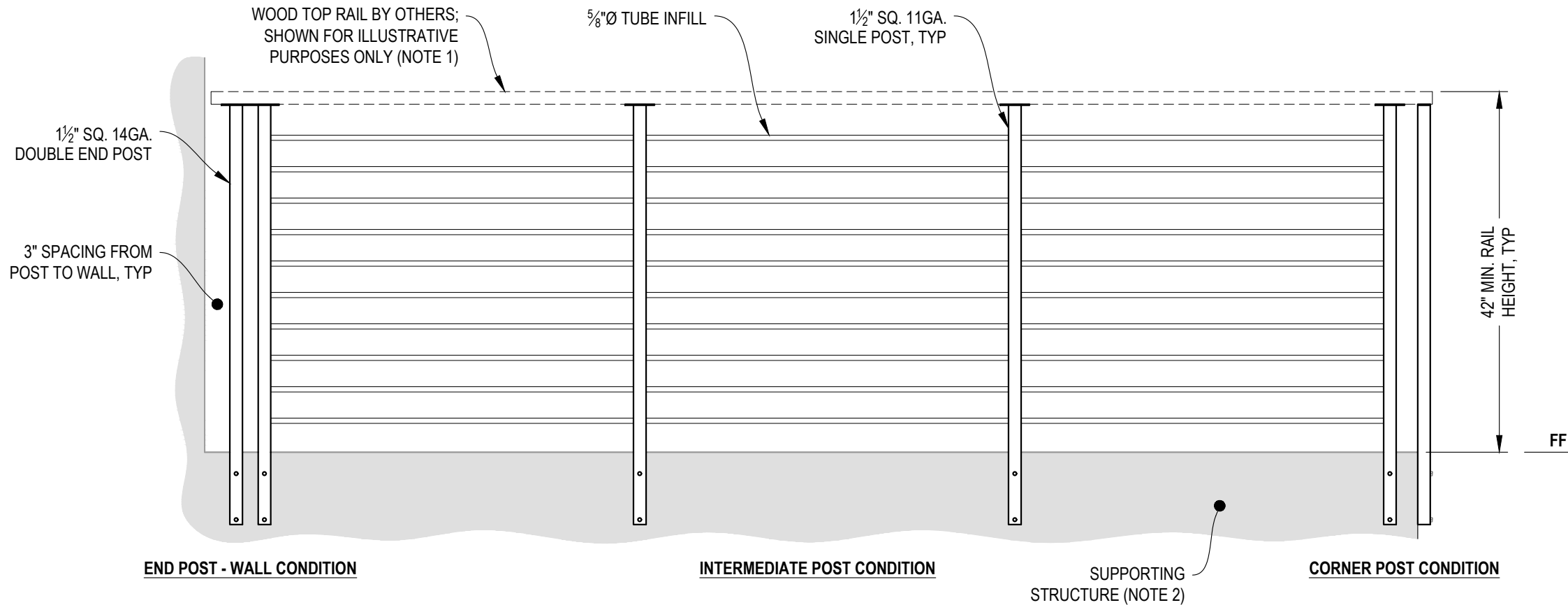

**A** **TYPICAL RAILING CONDITION**  
ELEVATION

**NOTES:**

1. TOP RAIL SHOULD BE SELECTED SO THAT ALL GOVERNING CODE REQUIREMENTS ARE SATISFIED. THESE INCLUDE SHAPE, STRENGTH AND RAILING HEIGHT.
2. DECK STRUCTURE CAN VARY GREATLY. IT IS THE RESPONSIBILITY OF THE CUSTOMER TO VERIFY THAT THE SUPPORTING STRUCTURE IS ADEQUATE TO MEET THE LOAD REQUIREMENTS OF THE GOVERNING BUILDING CODE(S). AGS Stainless Inc. RECOMMENDS CONSULTING A DESIGN OR CONSTRUCTION PROFESSIONAL TO ADDRESS THESE ISSUES.

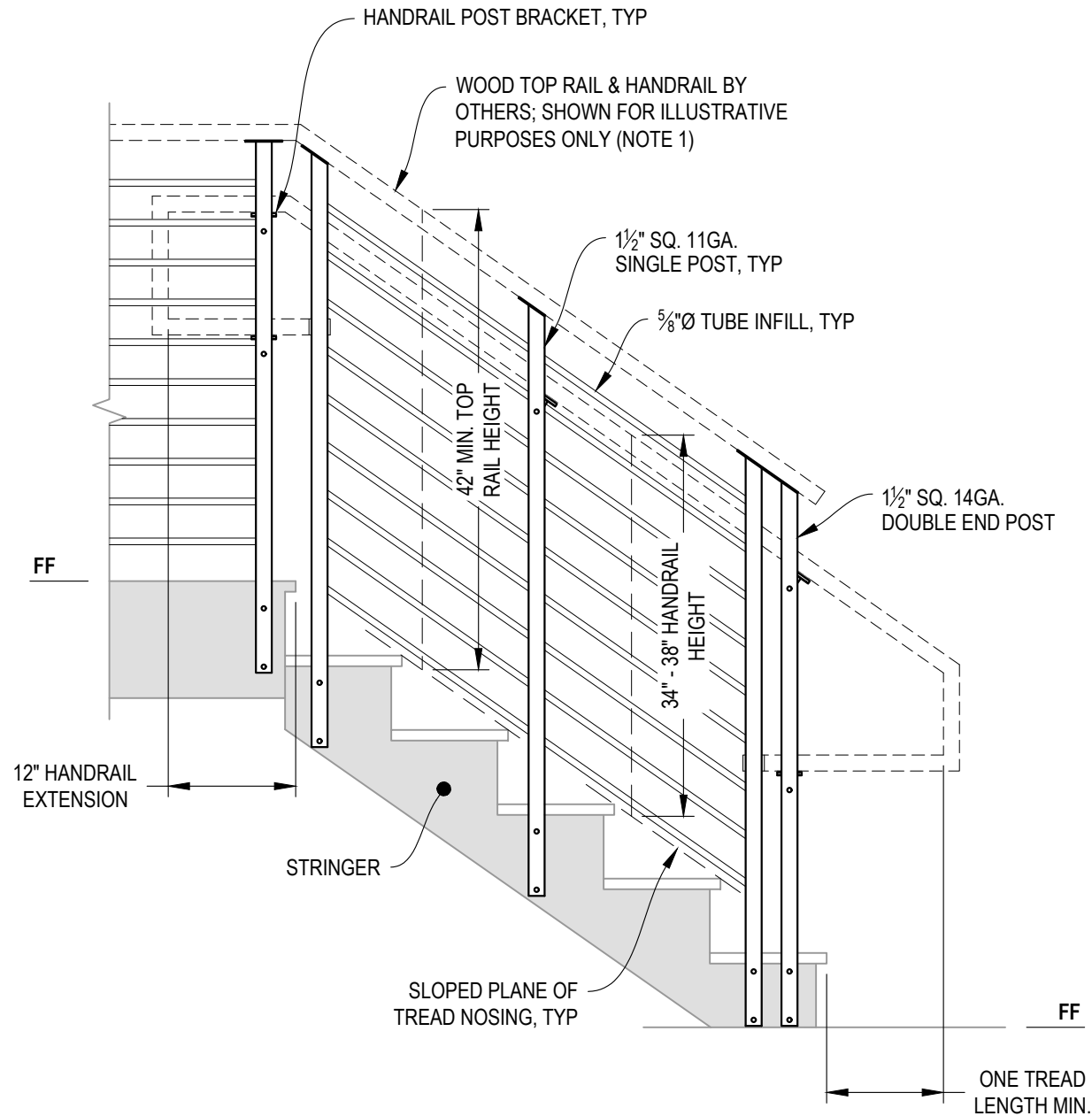

**A** STAIR ELEVATION

**NOTES:**

1. TOP RAIL SHOULD BE SELECTED SO THAT ALL GOVERNING CODE REQUIREMENTS ARE SATISFIED. THESE INCLUDE SHAPE, STRENGTH, AND RAILING HEIGHT.
2. STAIR CONSTRUCTION VARIES GREATLY. AS-BUILT CONDITIONS MAY ALTER RAILING DESIGN, INCLUDING POST LOCATION & MOUNTING, INFILL SPACING, AND TOP RAIL LAYOUT.

7873 NE DAY ROAD  
 BAINBRIDGE ISLAND, WA 98110  
 PHONE - (888) 842-9492  
 WWW.AGSSSTAINLESS.COM



OLYMPUS SPECIFICATION DRAWING  
 \*\* COMMERCIAL \*\*

42" SIDE MOUNT - WOOD TOP

DWG #	SM42WC
SCALE	NONE
DATE	2026
SHEET	

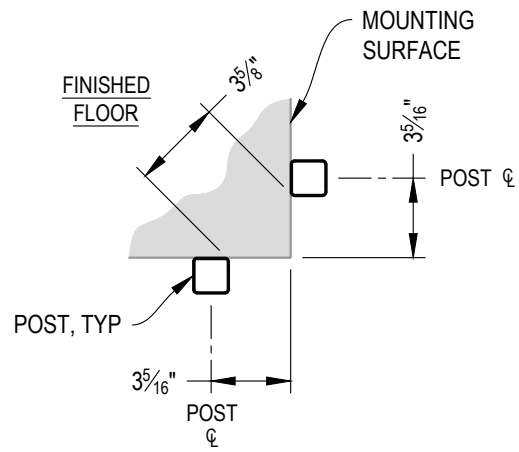

**A** TYPICAL 90° SIDE MOUNT OUTSIDE CORNER  
DETAIL

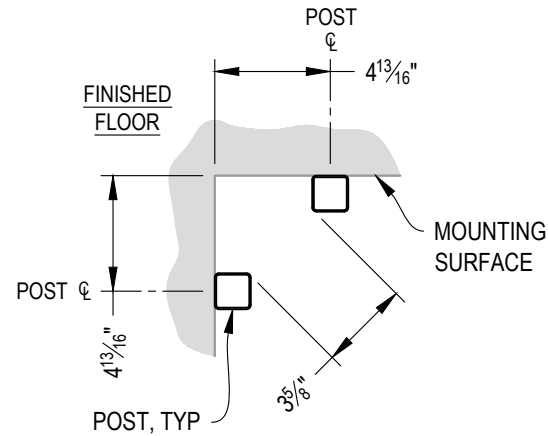

**B** TYPICAL 90° SIDE MOUNT INSIDE CORNER  
DETAIL

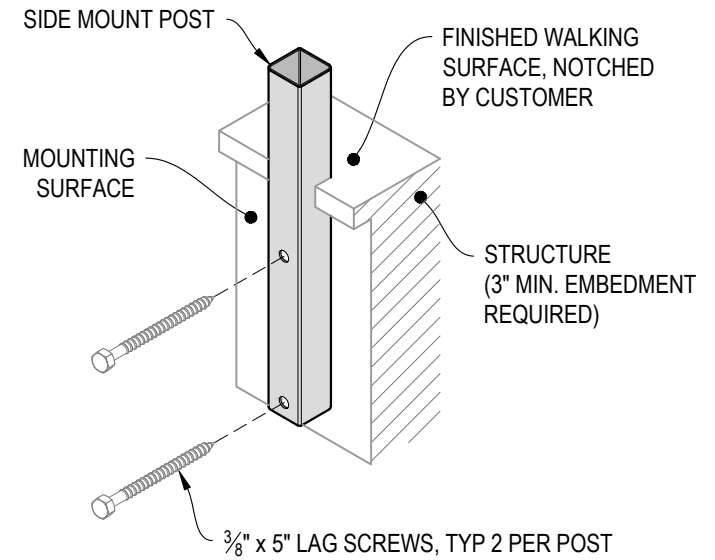

**C** TYPICAL POST MOUNTING - SIDE MOUNT  
DETAIL

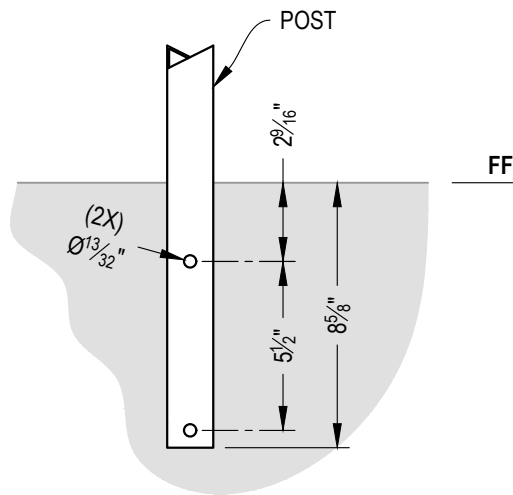

**D** TYPICAL POST MOUNTING - SIDE MOUNT  
DETAIL

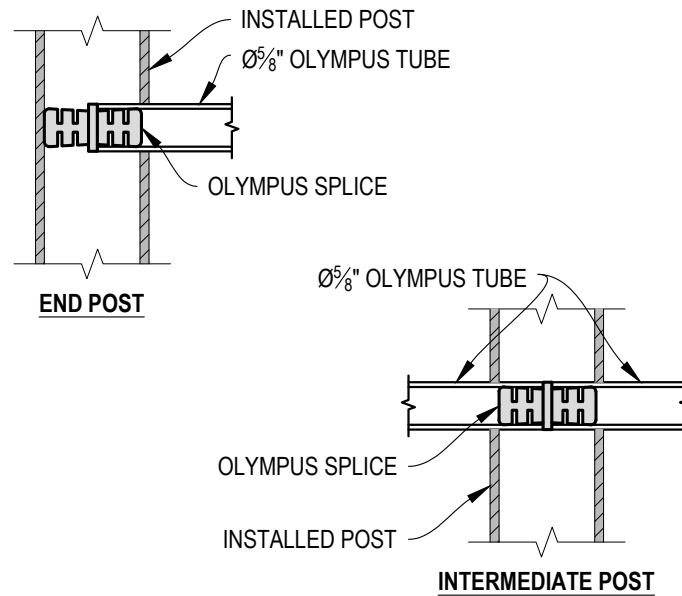

**E** FITTING INSTALLATION - OLYMPUS SPLICE  
DETAIL

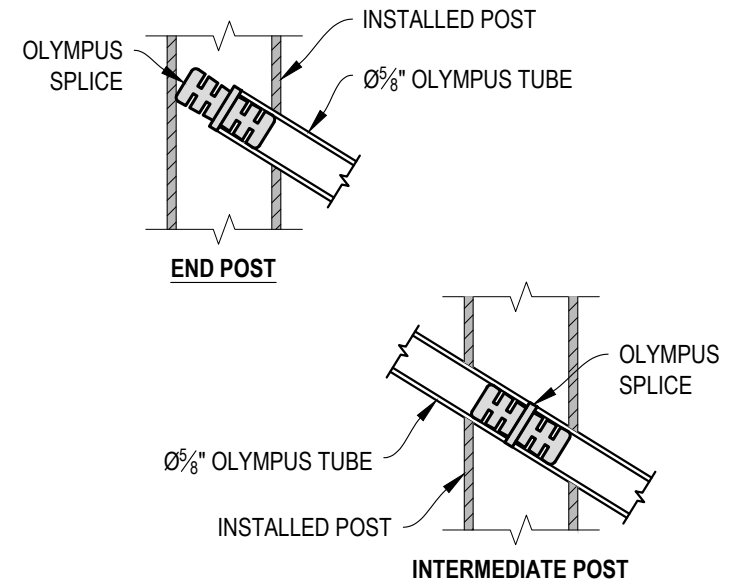

**F** FITTING INSTALLATION - OLYMPUS SPLICE  
DETAIL

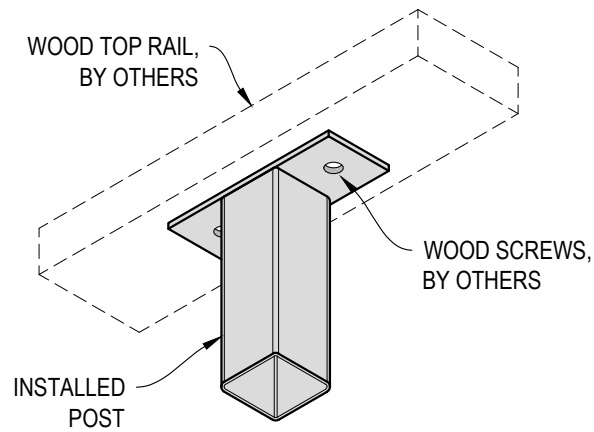

**A** TOP RAIL INSTALLATION - WOOD  
DETAIL

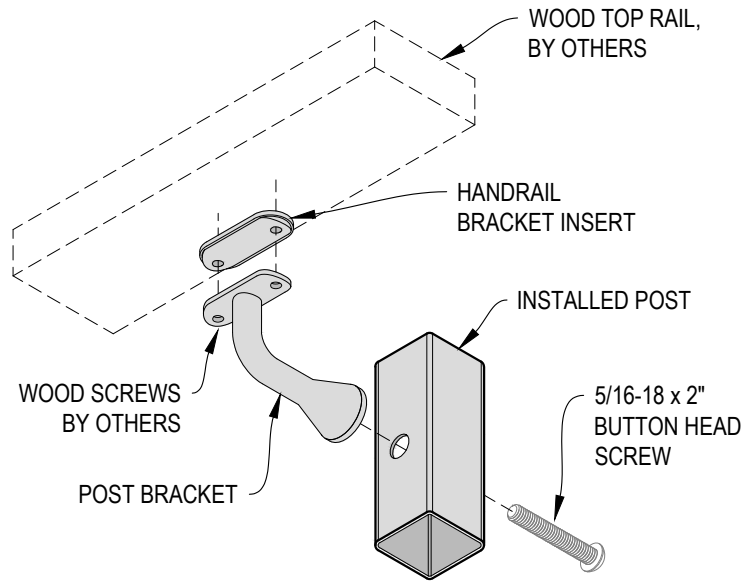

**B** HANDRAIL POST BRACKET INSTALLATION - WOOD  
DETAIL

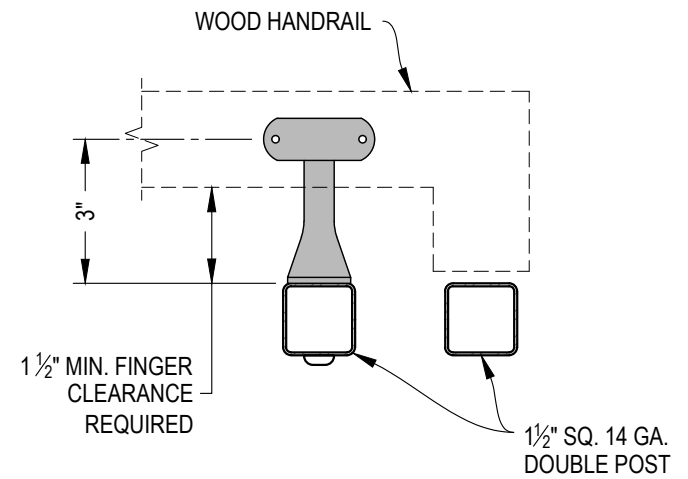

NOTE: VIEW MAY BE MIRRORED

**C** TYPICAL HANDRAIL RETURN - WOOD  
DETAIL

OLYMPUS SPECIFICATION DRAWING

\*\* COMMERCIAL \*\*

42" SIDE MOUNT - WOOD TOP

DWG # SM42WC  
SCALE NONE  
DATE 2026  
SHEET

5 OF 5

**AGS** stainless  
CLEARVIEW® Railing Systems

7873 NEDAY ROAD  
BAINBRIDGE ISLAND, WA 98110  
PHONE - (888) 842-9492  
WWW.AGSSTAINLESS.COM