

1 EXAMPLE POST LAYOUT
PLAN VIEW

NOTES:

1. TOP RAIL NOT SHOWN FOR CLARITY.
2. ALL PARTS AND COMPONENTS MADE WITH 316 STAINLESS STEEL UNLESS NOTED OTHERWISE.

LEGEND

- DETAIL ID
- SHEET ID
- ELEVATION ID
- SHEET ID
- SIDE MOUNT POST
- SIDE MOUNT DOUBLE POST
- CENTERLINE
- FINISHED FLOOR
- TYP TYPICAL CONDITION APPLIES ELSEWHERE AT SIMILAR CONDITIONS

NOTES:

1. DECK STRUCTURE CAN VARY GREATLY. IT IS THE RESPONSIBILITY OF THE CUSTOMER TO VERIFY THAT THE SUPPORTING STRUCTURE IS ADEQUATE TO MEET THE LOAD REQUIREMENTS OF THE GOVERNING BUILDING CODE(S). *AGS Stainless Inc.* RECOMMENDS CONSULTING A DESIGN OR CONSTRUCTION PROFESSIONAL TO ADDRESS THESE ISSUES.

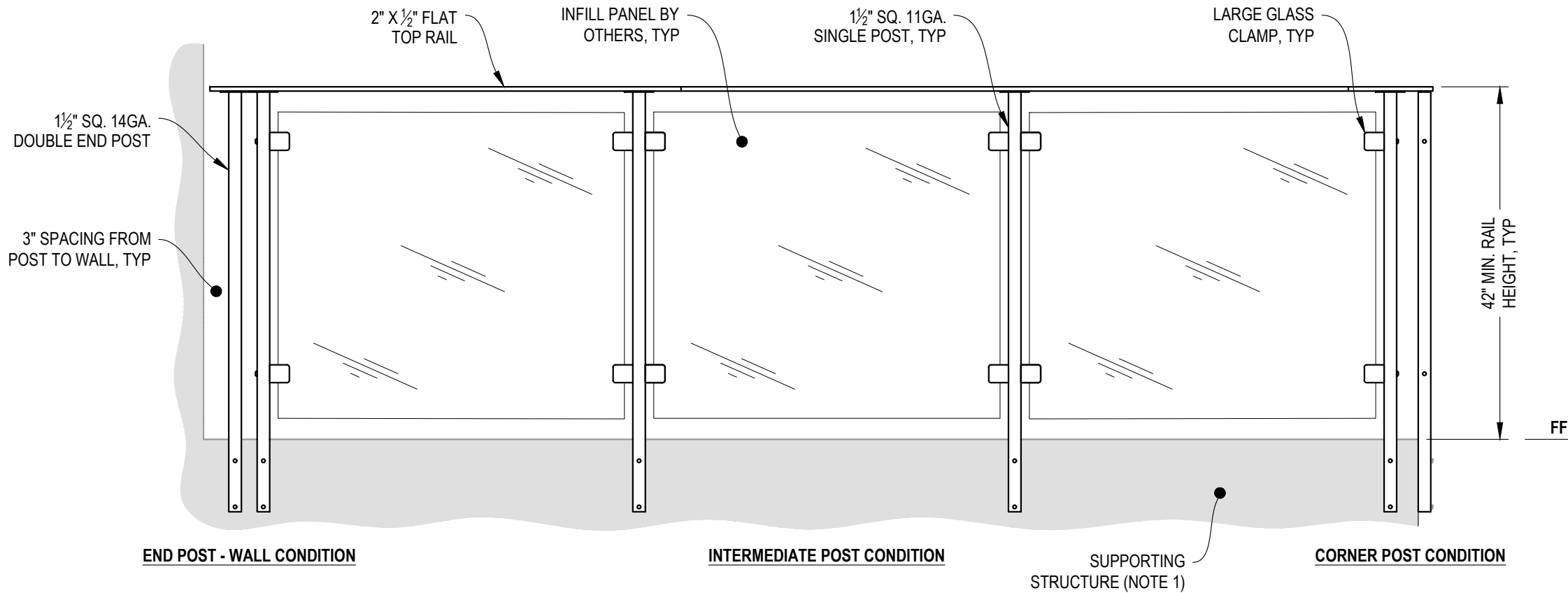

A **TYPICAL RAILING CONDITION**
ELEVATION

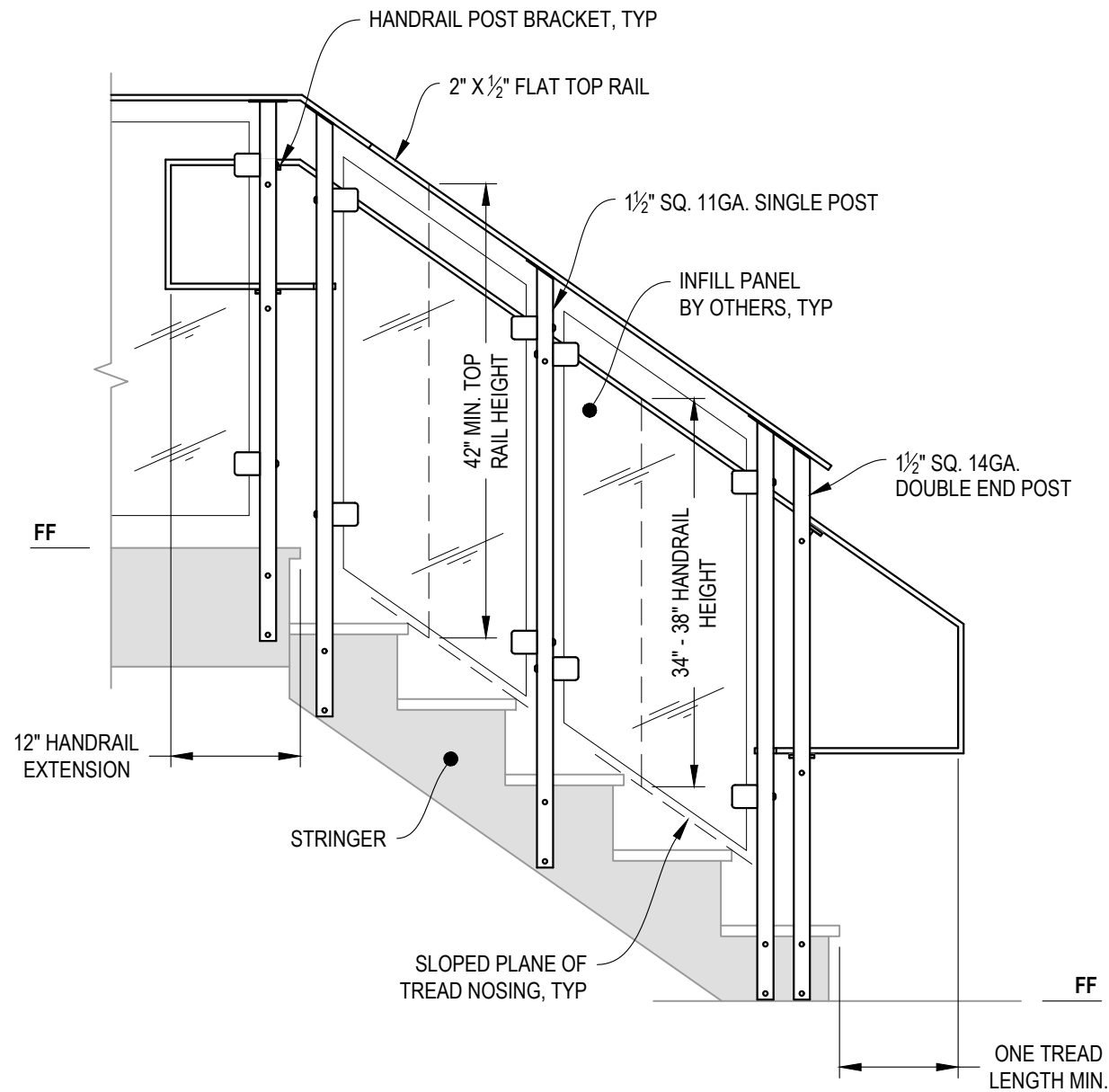

A STAIR ELEVATION

NOTES:

1. STAIR CONSTRUCTION VARIES GREATLY. AS-BUILT CONDITIONS MAY ALTER RAILING DESIGN, INCLUDING POST LOCATION & MOUNTING, INFILL SPACING, AND TOP RAIL LAYOUT.

7873 NEDAY ROAD
 BAINBRIDGE ISLAND, WA 98110
 PHONE - (888) 842-9492
 WWW.AGSSTAINLESS.COM



GLACIER SPECIFICATION DRAWING
 ** COMMERCIAL **

42" SIDE MOUNT - FLAT TOP

DWG # SM42FC

SCALE NONE

DATE 2026

SHEET

3 OF **5**

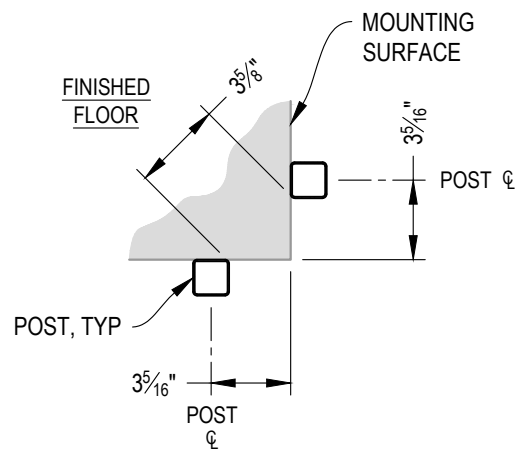

NOTE: 90° SHOWN, OTHER ANGLES SIMILAR

A TYPICAL 90° SIDE MOUNT OUTSIDE CORNER
DETAIL

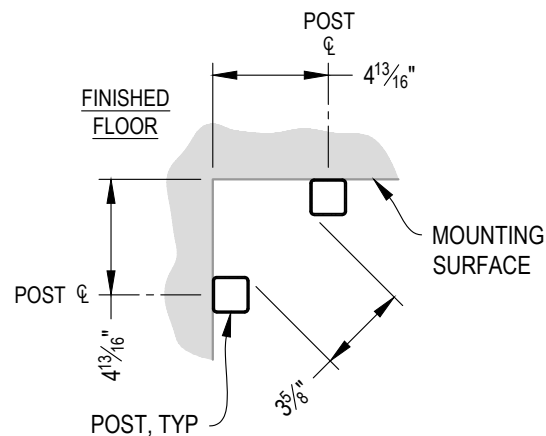

NOTE: 90° SHOWN, OTHER ANGLES SIMILAR

B TYPICAL 90° SIDE MOUNT INSIDE CORNER
DETAIL

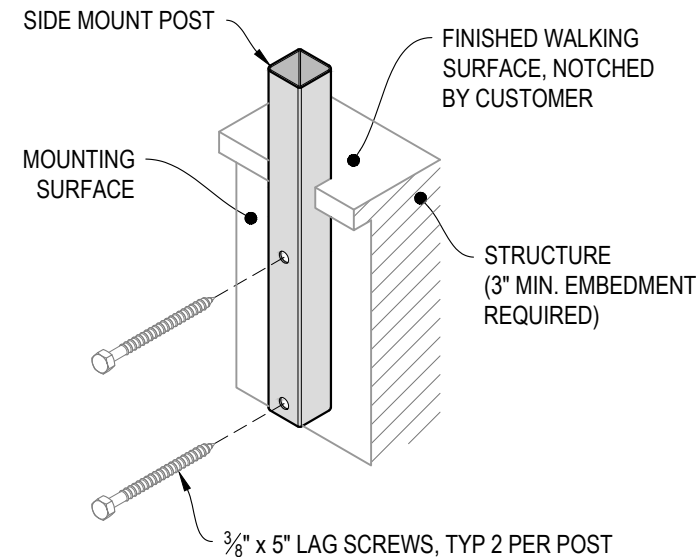

C TYPICAL POST MOUNTING - SIDE MOUNT
DETAIL

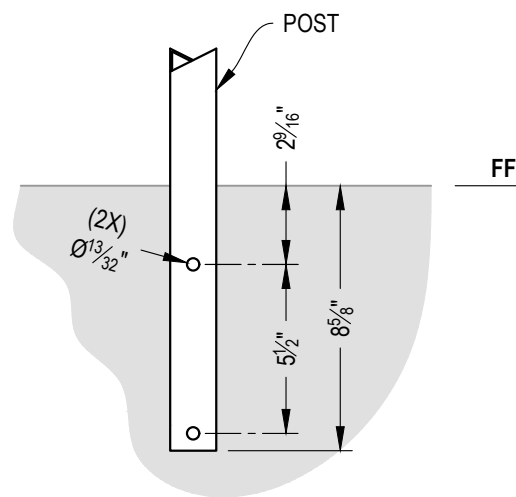

D TYPICAL POST MOUNTING - SIDE MOUNT
DETAIL

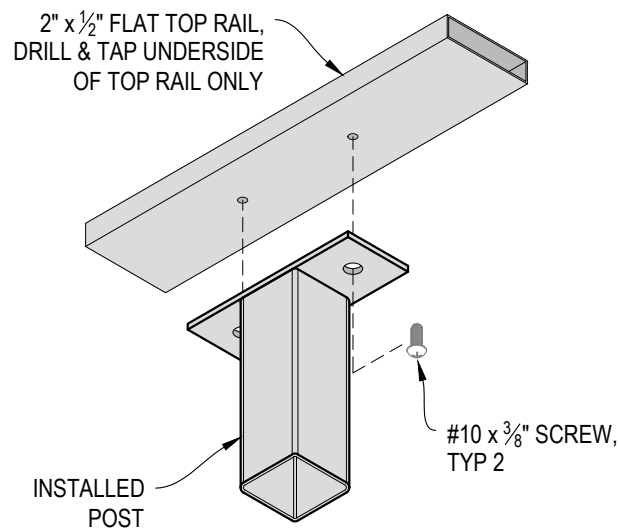

E TOP RAIL INSTALLATION - FLAT
DETAIL

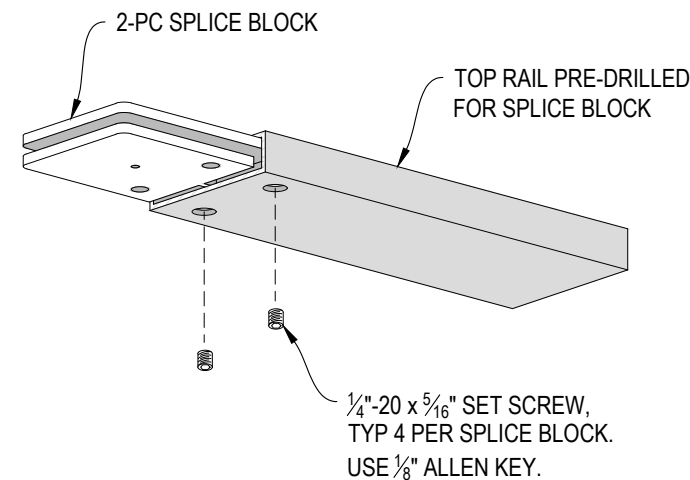

F SPLICE BLOCK ASSEMBLY - FLAT
DETAIL

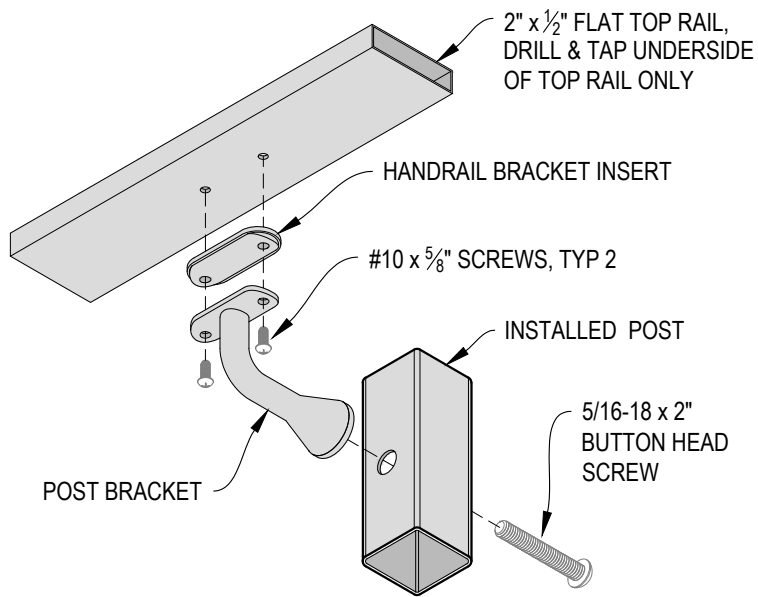

A HANDRAIL POST BRACKET INSTALLATION - FLAT
DETAIL

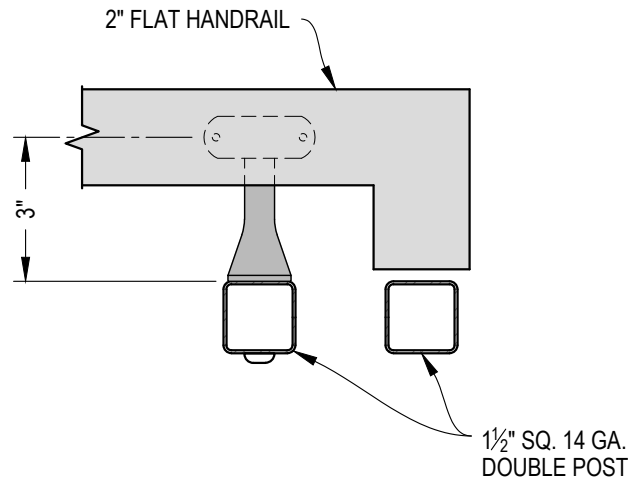

NOTE: VIEW MAY BE MIRRORED

B TYPICAL HANDRAIL RETURN - FLAT
DETAIL

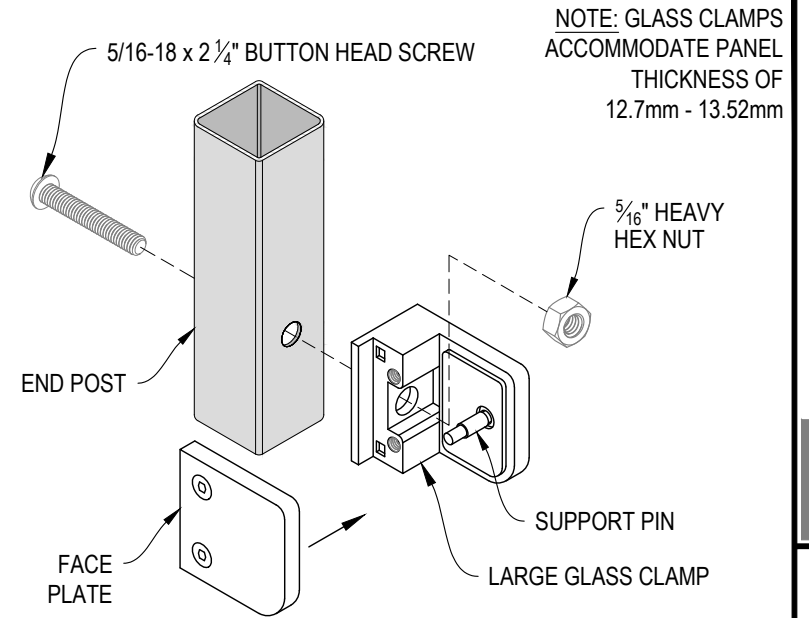

C END POST GLASS CLAMP INSTALLATION - LARGE
DETAIL

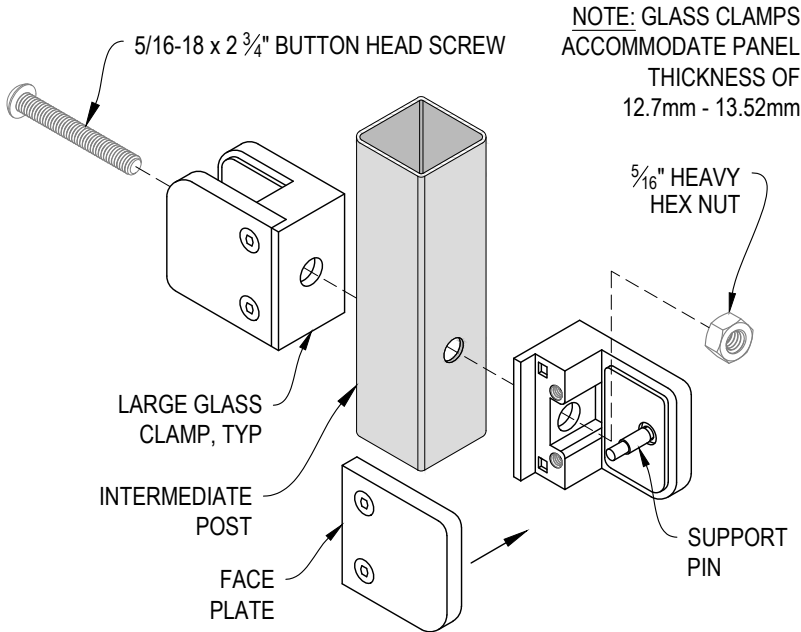

D INTERMEDIATE POST GLASS CLAMP INSTALLATION - LARGE
DETAIL

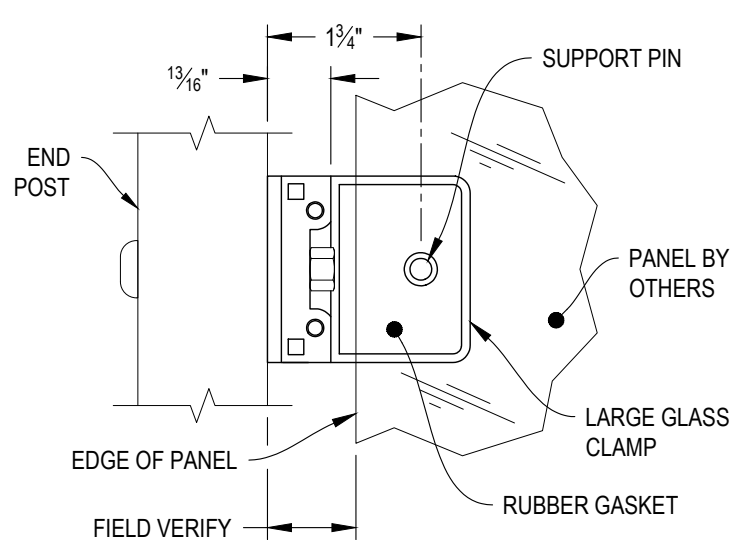

NOTE: FACE PLATE REMOVED FOR CLARITY.

E LARGE GLASS CLAMP WITH PIN
DETAIL

NOTE: GLASS CLAMPS
ACCOMMODATE PANEL
THICKNESS OF
12.7mm - 13.52mm

NOTE: GLASS CLAMPS
ACCOMMODATE PANEL
THICKNESS OF
12.7mm - 13.52mm

7873 NE DAY ROAD
BAINBRIDGE ISLAND, WA 98110
PHONE - (888) 842-9492
WWW.AGSSTAINLESS.COM

AGS stainless
CLEARVIEW® Railing Systems

GLACIER SPECIFICATION DRAWING

** COMMERCIAL **

42" SIDE MOUNT - FLAT TOP

DWG # SM42FC

SCALE NONE

DATE 2026

SHEET

5
OF 5