

**1** **EXAMPLE POST LAYOUT**  
PLAN VIEW

AGS Stainless Clearview® Railing Systems are designed to meet the requirements of the latest edition of the IRC/IBC.

**NOTES:**

1. TOP RAIL NOT SHOWN FOR CLARITY.
2. ALL PARTS AND COMPONENTS MADE WITH 316 STAINLESS STEEL UNLESS NOTED OTHERWISE.

**LEGEND**

- DETAIL ID
- SHEET ID
- ELEVATION ID
- SHEET ID
- CORE DRILL POST
- CORE DRILL DOUBLE POST
- CENTERLINE
- FF** FINISHED FLOOR
- TYP TYPICAL CONDITION APPLIES ELSEWHERE AT SIMILAR CONDITIONS

7873 NEDAY ROAD  
BAINBRIDGE ISLAND, WA 98110  
PHONE - (888) 842-9492  
WWW.AGSSTAINLESS.COM



GLACIER SPECIFICATION DRAWING  
\*\* COMMERCIAL \*\*  
42" CORE DRILL - FLAT TOP

DWG #	CD42FC
SCALE	NONE
DATE	2026
SHEET	

**NOTES:**

1. DECK STRUCTURE CAN VARY GREATLY. IT IS THE RESPONSIBILITY OF THE CUSTOMER TO VERIFY THAT THE SUPPORTING STRUCTURE IS ADEQUATE TO MEET THE LOAD REQUIREMENTS OF THE GOVERNING BUILDING CODE(S). *AGS Stainless Inc.* RECOMMENDS CONSULTING A DESIGN OR CONSTRUCTION PROFESSIONAL TO ADDRESS THESE ISSUES.

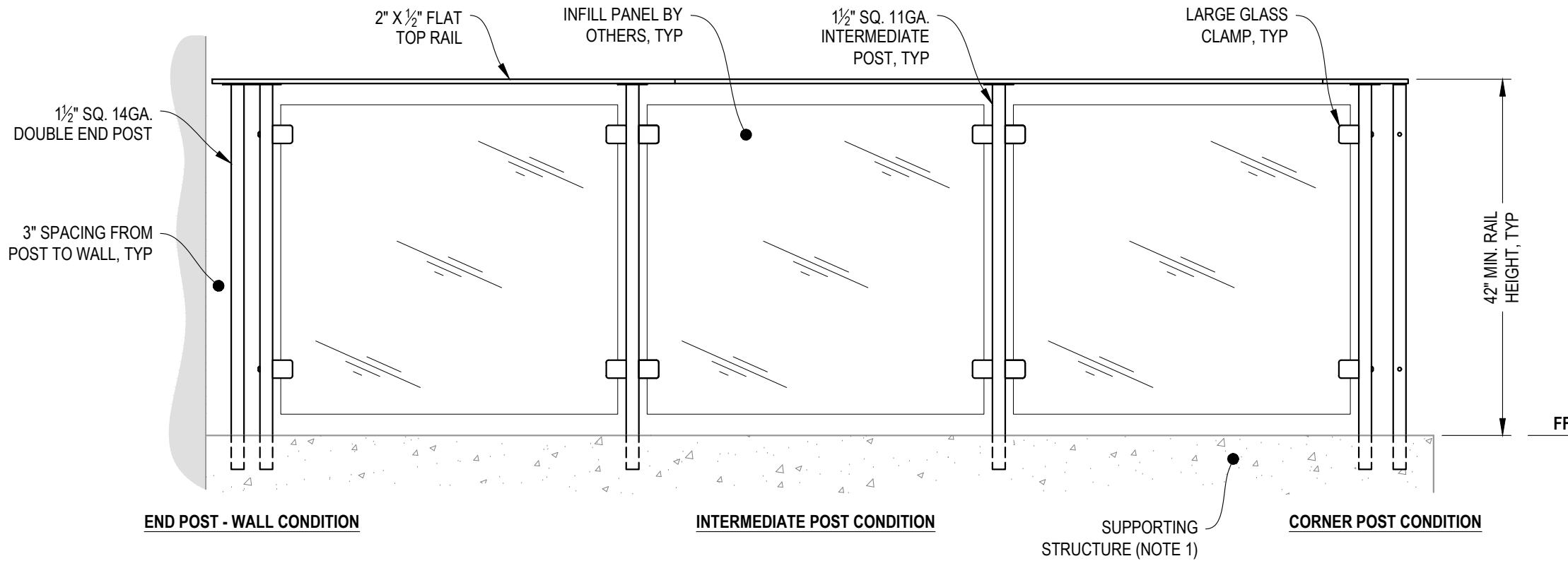

**A** TYPICAL RAILING CONDITION  
ELEVATION

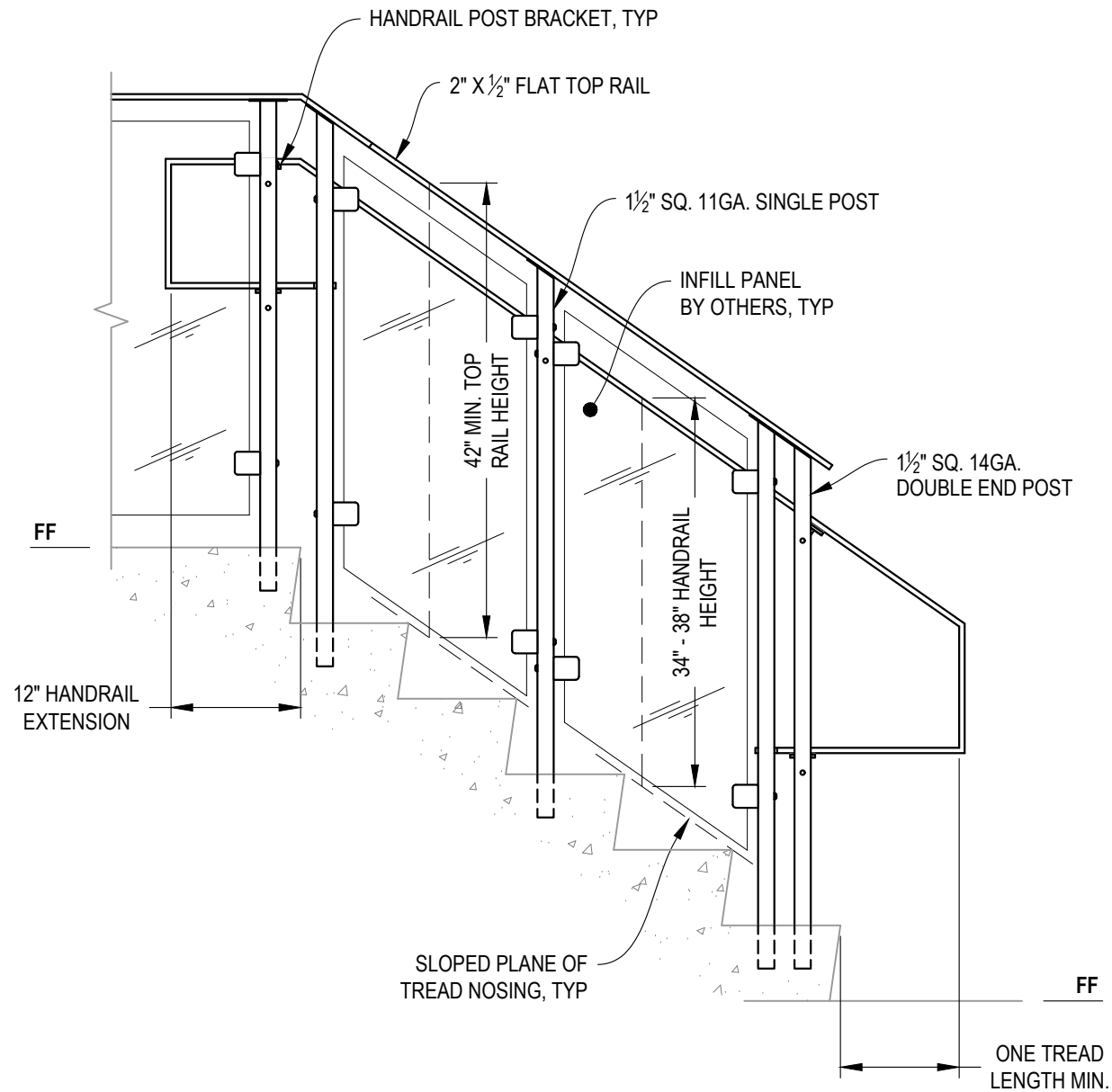

**A** STAIR ELEVATION

**NOTES:**

1. STAIR CONSTRUCTION VARIES GREATLY. AS-BUILT CONDITIONS MAY ALTER RAILING DESIGN, INCLUDING POST LOCATION & MOUNTING, INFILL SPACING, AND TOP RAIL LAYOUT.

7873 NEDAY ROAD  
 BAINBRIDGE ISLAND, WA 98110  
 PHONE - (888) 842-9492  
 WWW.AGSSTAINLESS.COM



GLACIER SPECIFICATION DRAWING

\*\* COMMERCIAL \*\*

42" CORE DRILL - FLAT TOP

DWG # CD42FC

SCALE NONE

DATE 2026

SHEET

**3** OF 5



NOTE: 90° SHOWN, OTHER ANGLES SIMILAR

**A** TYPICAL 90° TOP MOUNT OUTSIDE CORNER  
DETAIL



NOTE: 90° SHOWN, OTHER ANGLES SIMILAR

**B** TYPICAL 90° TOP MOUNT INSIDE CORNER  
DETAIL

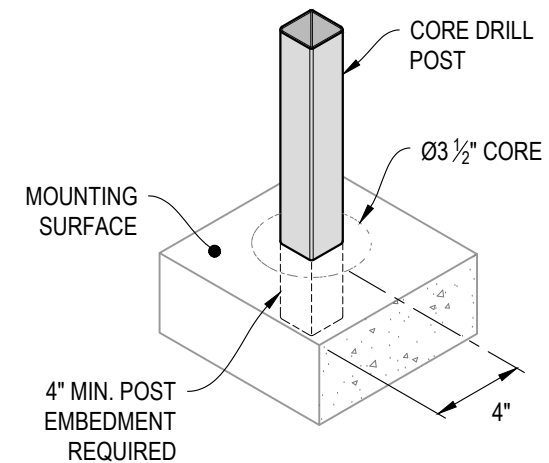

**C** TYPICAL POST MOUNTING - CORE DRILL  
DETAIL

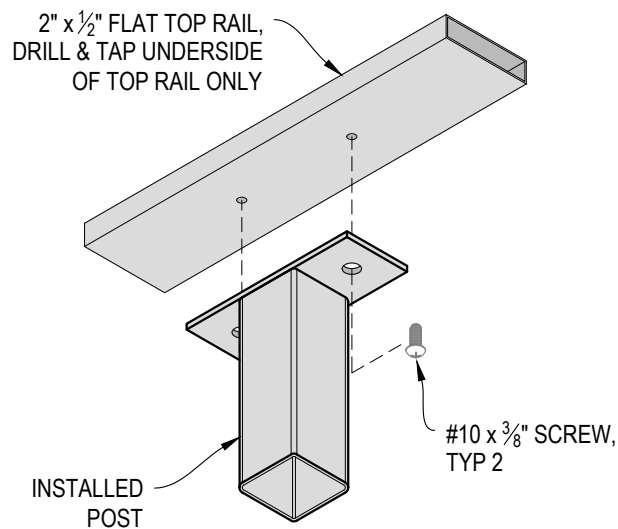

**D** TOP RAIL INSTALLATION - FLAT  
DETAIL

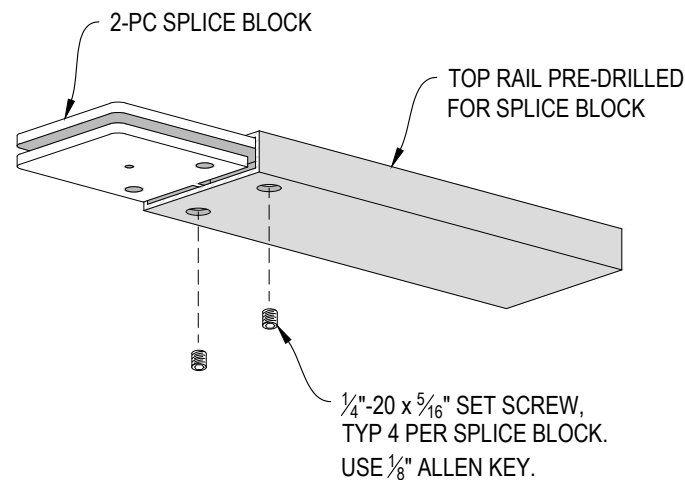

**E** SPLICE BLOCK ASSEMBLY - FLAT  
DETAIL

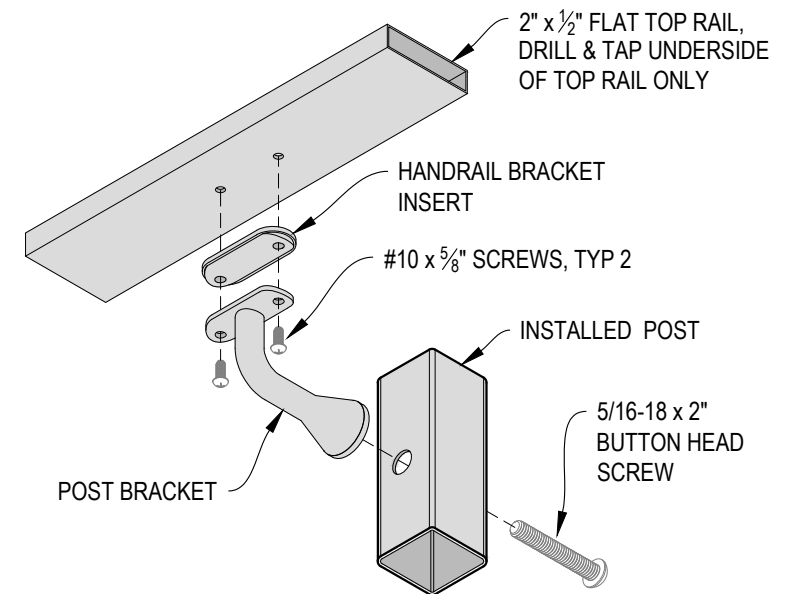

**F** HANDRAIL POST BRACKET INSTALLATION - FLAT  
DETAIL

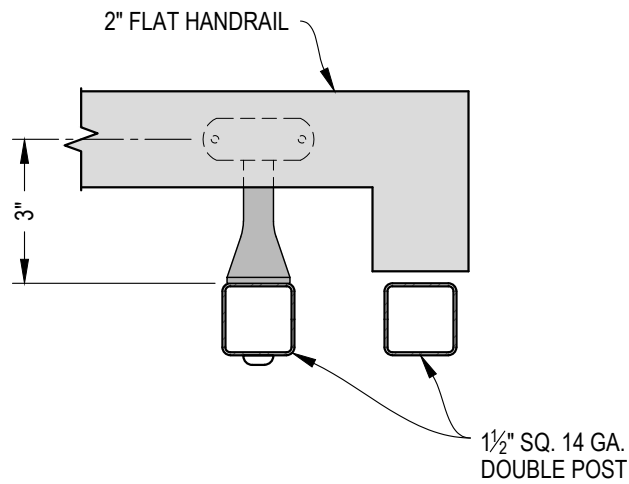

NOTE: VIEW MAY BE MIRRORED

**A** TYPICAL HANDRAIL RETURN - FLAT  
DETAIL

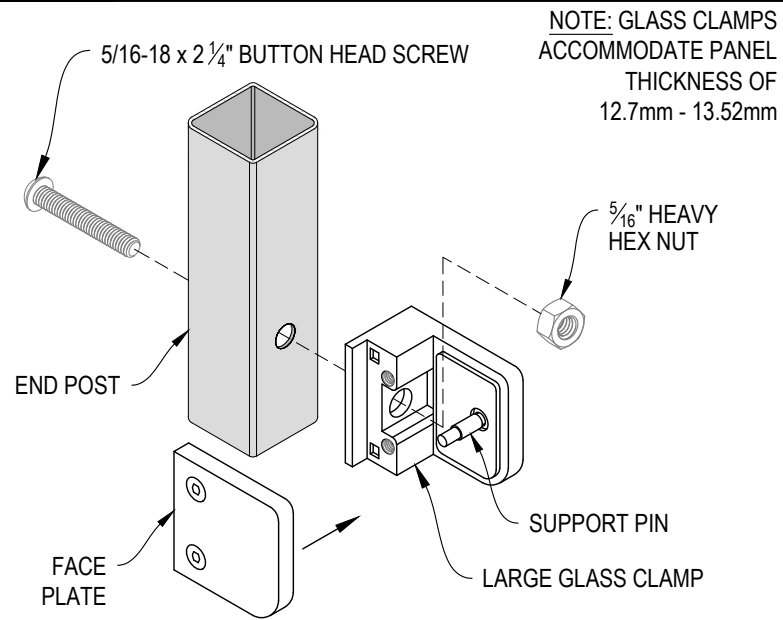

**B** END POST GLASS CLAMP INSTALLATION - LARGE  
DETAIL

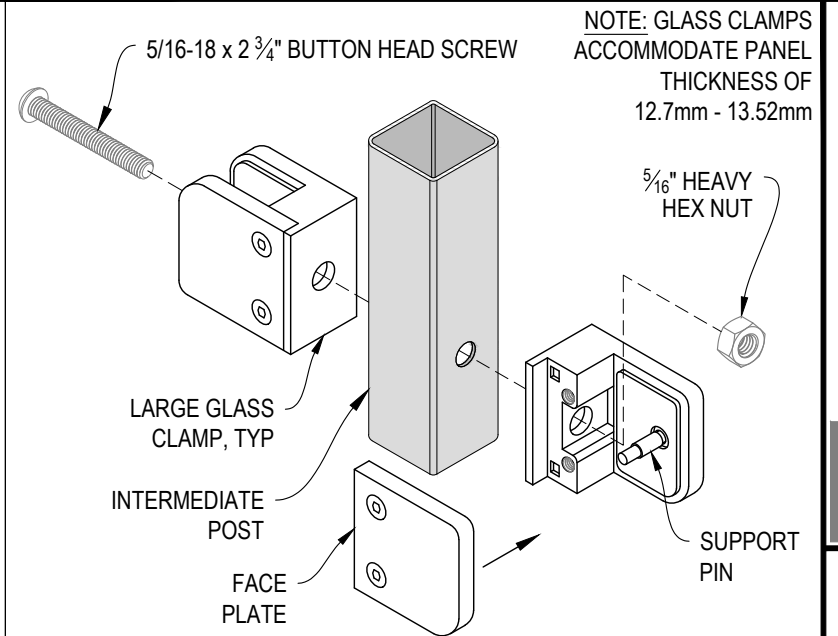

**C** INTERMEDIATE POST GLASS CLAMP INSTALLATION - LARGE  
DETAIL

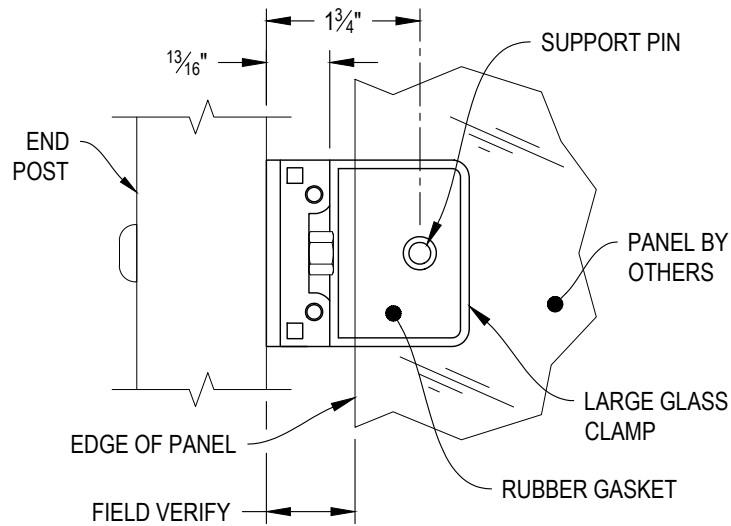

NOTE: FACE PLATE REMOVED FOR CLARITY.

**D** LARGE GLASS CLAMP WITH PIN  
DETAIL